

Cooling and heating systems

Induction unit for displacement ventilation, for vertical parapet mounting, type IG-Q-SB

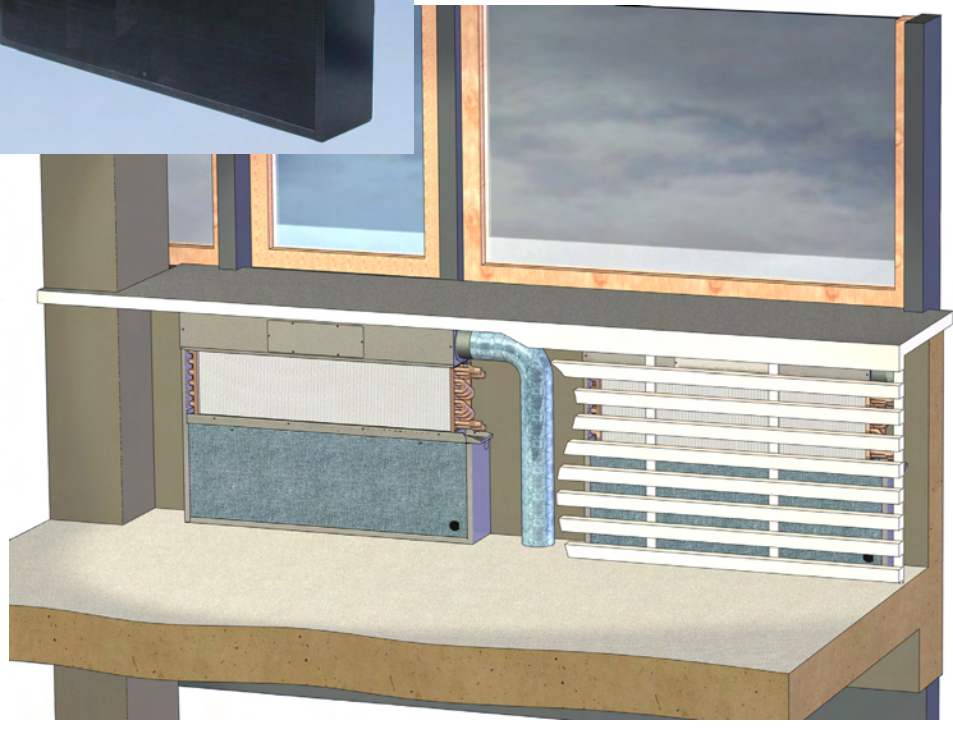
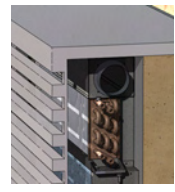

DS 4129 E 10.2007

Technical Selection

Preliminary remark

For removing the cooling and heating loads of buildings whose facades are fitted with window parapets, KRANTZ KOMPONENTEN provides induction units for displacement ventilation.

In the cooling mode, displacement ventilation enables to deliver supply air to workplaces with great efficiency and to extract heat from the occupied zone very efficiently owing to the vertical indoor air temperature gradient.

The induction unit for displacement ventilation belongs to the line of air-and-water systems where the outdoor air flow rate required for reasons of hygiene is conditioned in a central air handling unit and the cooling or heating load removed via a 4-pipe water system. Air-and-water systems are much more economical than pure air systems (such as VAV systems).

Construction design and mode of operation

The induction unit for displacement ventilation (Fig. 1) consists of a housing 1 with primary air connection 2. Inside the primary air box 3, the primary air is conveyed by nozzles 4 to the induction area 5 in front of the heat exchanger 6. The heat exchanger has usually a 4-pipe design, yet a 2-pipe design can be provided on request in the case change-over operation is required. The water control valves can be positioned near the unit.

Owing to the suction effect of the nozzle jets, secondary air 7 is sucked in via the heat exchanger 6 where it is either heated or cooled. The blend of primary and secondary air forms supply air 8 which is discharged into the room via the unit's air outlet 9 arranged behind the lower part of the parapet cover 10 (provided by the client). In this area as well as in the area of secondary air intake, the parapet cover must be so constructed as to let air in and out. Further, there must be a screen 11 (horizontal and vertical at the sides) between the supply air zone and the secondary air zone in order to prevent any short-circuit between supply air discharge and secondary air intake behind the parapet cover.

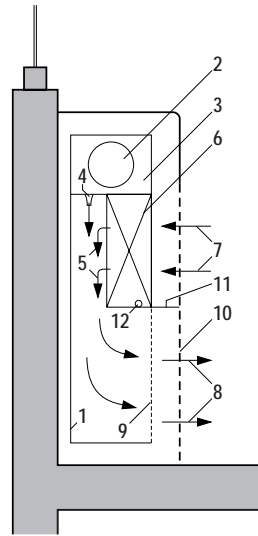

Fig. 1: Design and mode of operation of the induction unit for displacement ventilation, with secondary air intake at the front

Key

1 Housing	7 Secondary air
2 Primary air connection	8 Supply air
3 Primary air box	9 Air outlet
4 Nozzle	10 Parapet cover
5 Induction area	11 Screen
6 Heat exchanger	12 Condensate drain

It is also possible to have the secondary air 7 sucked in through the top instead of the front of the parapet cover (Fig. 2), but then this area must have appropriate apertures for air (perforations or slots). The requisite free areas are indicated in Fig. 6 on page 4. This arrangement has a favourable effect on the air flow pattern and the heating output is higher.

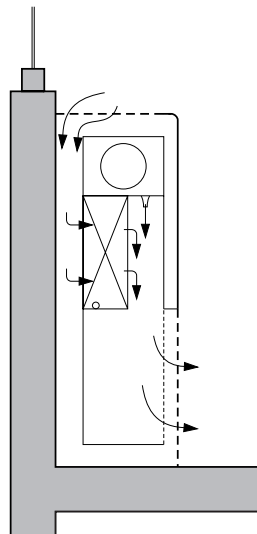

Fig. 2: Design and mode of operation of the induction unit for displacement ventilation, with secondary air intake at the top

When heating at weekends or at night, primary air is not required; the induction unit for displacement ventilation then operates with self-convection, which saves energy (see Fig. 3 and 4).

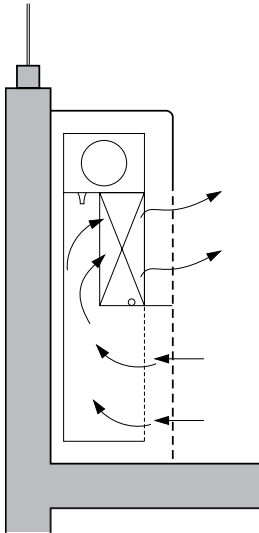

Fig. 3: Operation with self-convection,
secondary air at the front

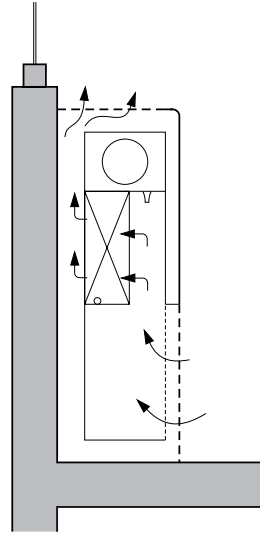

Fig. 4: Operation with self-convection,
secondary air at the top

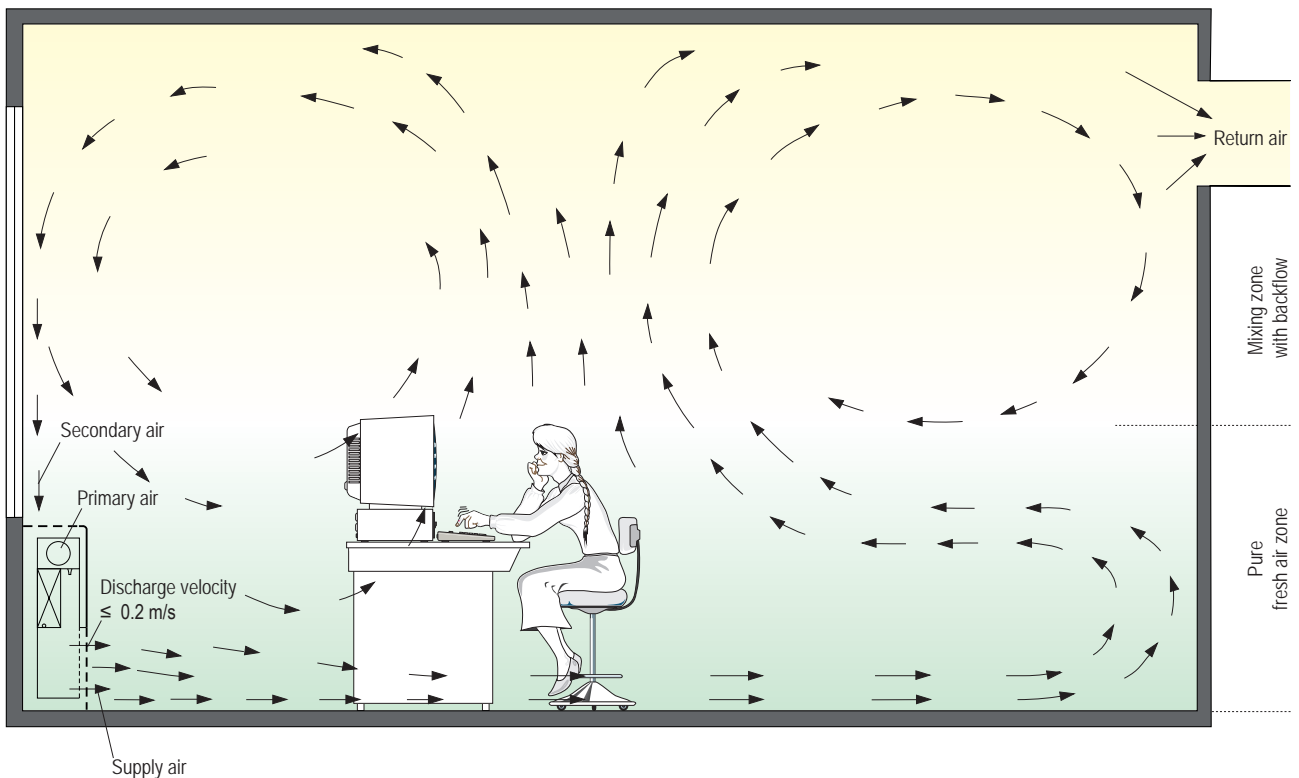
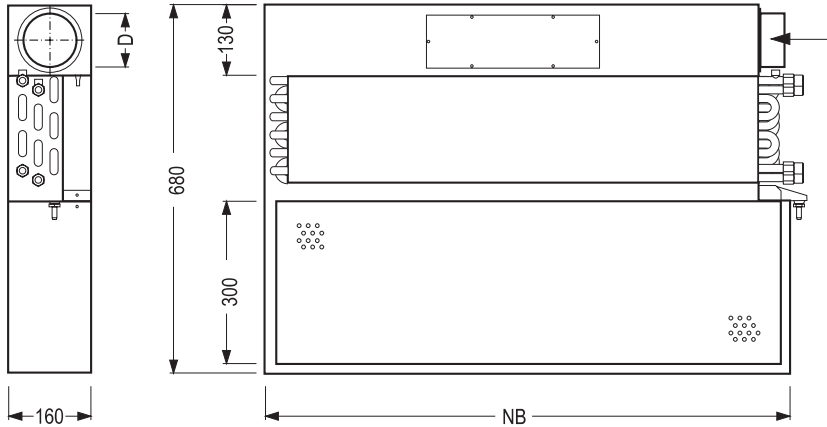

Fig. 5: Air flow pattern



Nominal unit width NB mm	Width of heat exchanger = Discharge width L mm	Connection spigot for primary air D in mm		Weight approx. kg
		6 and 7	8	
800	610	79	99	22.0
1000	810	99	124	25.5
1200	1010	99	124	29.0

Fig. 6: Unit dimensions

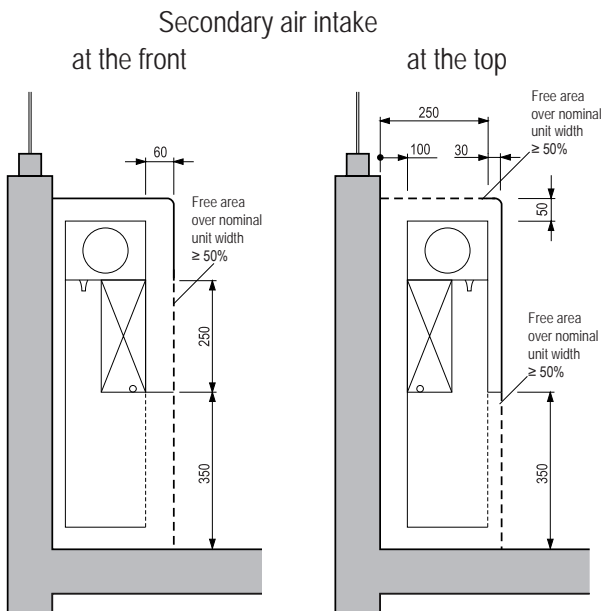

Fig. 7: Minimum spacing for ensuring proper secondary air reflow

Technical selection

Cooling

The cooling output of the induction unit for displacement ventilation is made up of the water-side (secondary air) and primary air-side cooling outputs. Table 1 shows a preselection.

The water-side cooling output, which is delivered via the secondary air, is dependent on the primary air volume flow rate and the difference between mean water temperature and secondary air temperature. Graph 1 (page 5) shows standard outputs per metre of air discharge width

Table 1: Preselection for cooling
for $\Delta p = 170 \text{ Pa}$ and $L_{WA} \leq 29 \text{ dB (A)}$

Nominal unit width mm	Primary air volume flow rate		Nozzle diameter mm	Water flow l/h	Cooling output ¹⁾ Secondary air W	Cooling output ²⁾ Primary air W	Total cooling output W	Total specific cooling output ³⁾ W/m ²
	l/s	m ³ /h						
800	7	25	6	70	145	50	195	32
	10	35	7	73	169	71	240	40
	14	50	8	87	202	101	303	50
1000	8	30	6	76	176	60	236	33
	13	45	7	94	219	91	310	43
	17	60	8	106	248	121	369	52
1200	11	40	6	100	232	81	313	38
	15	55	7	115	269	111	380	46
	22	80	8	140	326	161	487	59

1) Supply/Return temperature 18/20°C, secondary air temperature 24°C

2) Primary air temperature 20°C, return air temperature 26°C

3) Room axis-to-axis dimension: (nominal unit width + 300 mm) x room depth 5.5 m

'L' (= heat exchanger width) for a difference of -5 K, e.g. secondary air temperature 24 °C (roughly corresponding to the indoor air temperature in the occupied zone), supply temperature 18 °C, return temperature 20 °C and mean water temperature 19 °C. If a primary air temperature of 20 °C is selected, the supply air temperature will also be 20 °C; this is the minimum value for supply air to ensure a high level of thermal comfort with a displacement ventilation system.

For other layout cases, the outputs shown in Graph 1 can be converted in a linear way, e.g. for a difference of 6 K instead of 5 K between mean water temperature and secondary air temperature, the conversion factor is 6/5 K and, thus, the conversion is 1.2 x output as per Graph 1. Yet, at higher cooling outputs, the vertical room temperature gradient is higher. If a pressure loss higher than

170 Pa or a sound power level higher than 29 dB(A) is allowable, the maximum specific primary air volume flow rates can be selected according to this graph at the relevant nozzle diameters.

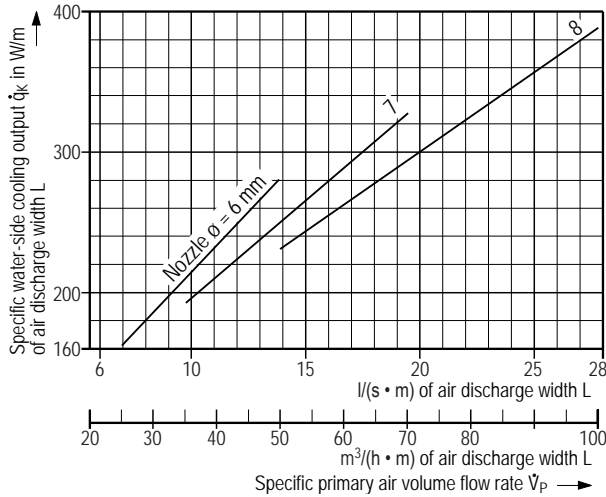

Graph 1: Specific water-side cooling output at a difference of -5 K between mean water temperature and secondary air temperature

The primary air-side cooling output depends on the primary air volume flow rate and, in displacement air systems, on the difference between supply air and return air temperatures. The standard layout is often made at a difference of -6 K , i.e. with a primary air temperature of $20\text{ }^\circ\text{C}$ and a return air temperature of $26\text{ }^\circ\text{C}$. In such case, the indoor air temperature in the occupied zone is $2\text{-}3\text{ K}$ under the return air temperature, i.e. about $23\text{-}24\text{ }^\circ\text{C}$. Graph 2 shows cooling outputs for this and other temperature differences, in relation to the primary air volume flow rate. The outputs are independent of the unit size, i.e. they are influenced only by the primary air volume flow rate and the temperature difference.

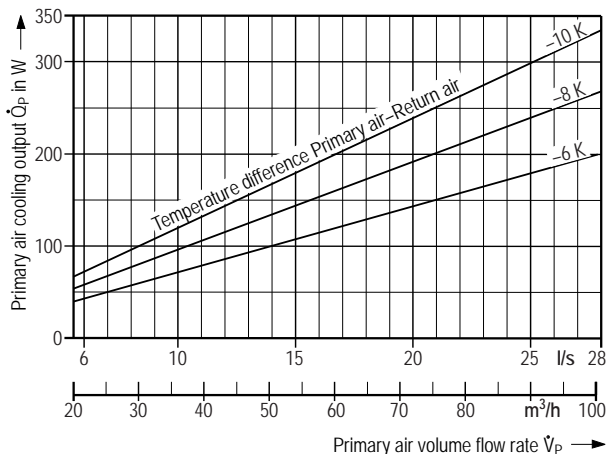

Graph 2: Primary air-side cooling output

The total cooling output of the induction unit is the sum of primary air output and secondary air output (water-side).

Heating

The heating output of the induction unit is delivered economically via the secondary air, i.e. via the heat exchanger. Values are given in Table 2 (for secondary air intake at the top) and Table 3 (for secondary air intake at the front) for various nominal unit widths and nozzle diameters in order to facilitate the preselection. Additional heating output can be delivered via the primary air but, as a rule, this is not necessary because of the high water-side outputs.

Table 2: Preselection for heating
for $\Delta p = 170\text{ Pa}$ and $L_{WA} \leq 29\text{ dB(A)}$
Secondary air intake at the top

Nominal unit width mm	Primary air volume flow rate		Nozzle diameter mm	Water flow l/h	Heating output ¹⁾ Secondary air W	Specific heating output ²⁾ W/m ²
	l/s	m ³ /h				
800	7	25	6	70	326	54
	10	35	7	70	364	60
	14	50	8	70	407	67
1000	8	30	6	70	402	56
	13	45	7	81	473	66
	17	60	8	88	509	71
1200	11	40	6	91	526	64
	15	55	7	100	582	71
	22	80	8	113	660	80

¹⁾ Supply/Return temperature $40/35\text{ }^\circ\text{C}$, primary and secondary air temperature $22\text{ }^\circ\text{C}$

²⁾ Room axis-to-axis dimension: (nominal unit width + 300 mm) x room depth 5.5 m

In winter, if the primary air is supplied at a temperature lower than that of the indoor air, additional heating is required which, besides transmission heat losses of the building, is to be covered by the secondary air. This is for instance the case when other interior spaces are to be provided with cooling from the central plant in winter too.

Table 3: Preselection for heating
for $\Delta p = 170 \text{ Pa}$ and $L_{WA} \leq 29 \text{ dB (A)}$
Secondary air intake at the front

Nominal unit width mm	Primary air volume flow rate		Nozzle diameter mm	Water flow l/h	Heating output ¹⁾ Secondary air W	Specific heating output ²⁾ W/m ²
	l/s	m ³ /h				
800	7	25	6	70	261	43
	10	35	7	70	319	53
	14	50	8	70	385	64
1000	8	30	6	70	314	44
	13	45	7	71	411	57
	17	60	8	80	468	65
1200	11	40	6	72	418	51
	15	55	7	86	503	61
	22	80	8	106	619	75

¹⁾ Supply/Return temperature 40/35 °C, primary and secondary air temperature 22 °C
²⁾ Room axis-to-axis dimension: (nominal unit width + 300 mm) x room depth 5.5 m

Graph 3 (for secondary air intake at the top) and Graph 4 (for secondary air intake at the front) show outputs for a difference of 15 K between mean water temperature and secondary air temperature. Other values can be converted in a linear way.

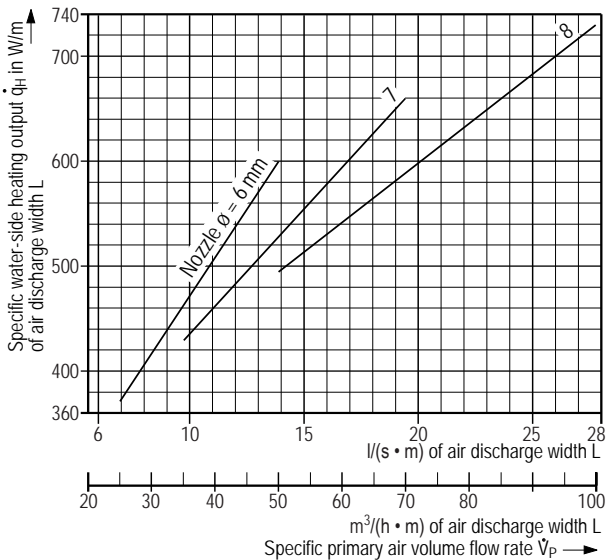

Graph 3: Specific water-side heating output at a difference of +15 K between mean water temperature and secondary air temperature, with secondary intake at the top

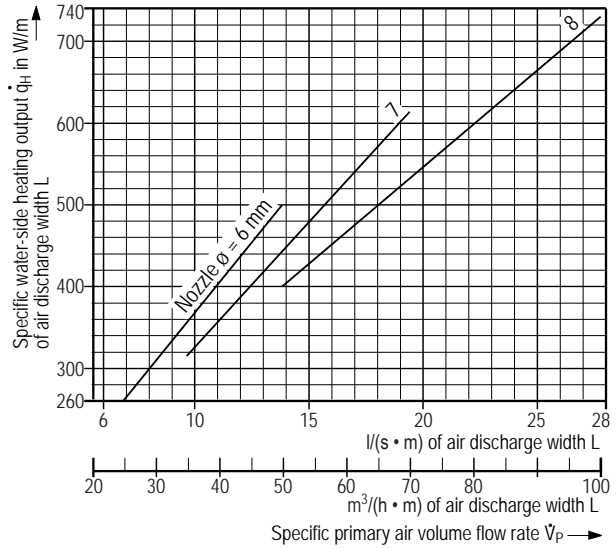

Graph 4: Specific water-side heating output at a difference of +15 K between mean water temperature and secondary air temperature, with secondary intake at the front

The induction unit for displacement ventilation can also be operated with pure self-convection, without primary air (Fig. 3 + 4 on page 3). For the purposes of economy this is mainly used at night and at weekends. Related heating outputs can be read off Graph 5 (for secondary air “at the top”) and Graph 6 (for secondary air “at the front”); they apply for a water flow rate of 70 l/h. At a higher water flow rate, the heating output rises a little, e.g. by 3% at 100 l/h.

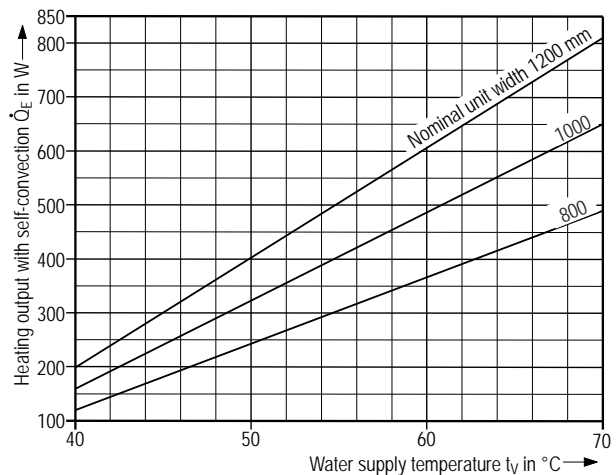

Graph 5: Heating output with self-convection, with secondary air “at the top”, room temperature 22 °C, water flow rate 70 l/h

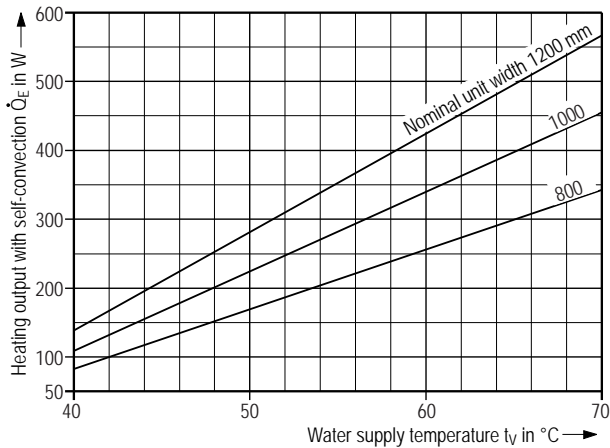

Graph 6: Heating output with self-convection, with secondary air "at the front", room temperature 22 °C, water flow rate 70 l/h

Sound power level and pressure loss

The sound power level is shown in Graph 7 in relation to the specific primary air volume flow rate.

To read it from the graph, you must first adapt the volume flow rate of the selected nominal unit width to the air discharge width (see Fig. 6 on page 4).

Example:

Nominal unit width:	1000 mm
Air discharge width:	810 mm
Primary air volume flow rate:	14 l/s [50 m ³ /h]
Specific primary air volume flow rate related to air discharge width:	17 l/(s · m) [62 m ³ /(h · m)]
Nozzle diameter:	7 mm
Sound power level:	29 dB(A) ref. 10 ⁻¹² W

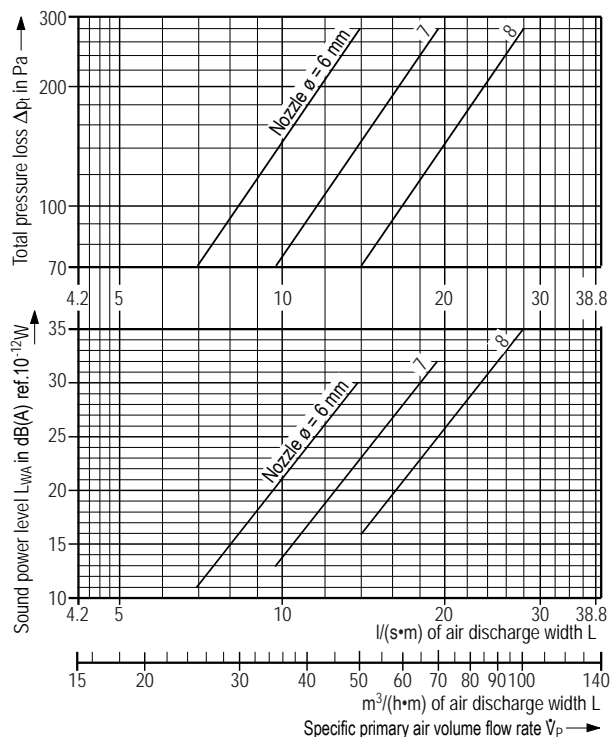

The pressure loss on the primary air side is shown in Graph 7 in relation to the specific primary air volume flow rate. To read it from the graph, you must first adapt the volume flow rate of the selected nominal unit width to the air discharge width.

The pressure loss on the water side, i.e. in the secondary air heat exchanger, is shown in Graph 8 for heating and cooling respectively.

The minimum water flow rate for all unit sizes is 70 l/h.

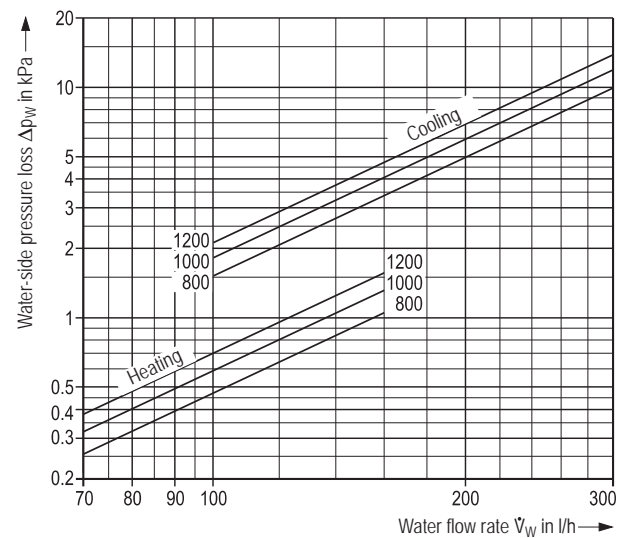

Graph 8: Water-side pressure loss of heat exchanger

Features

- For cooling, heating, and fresh air supply along the facade, through window parapets; high level of thermal comfort
- Low-turbulence supply air discharge at low momentum according to the principle of displacement ventilation
- Primary air volume flow rate: 7 to 22 l/s [25 to 80 m³/h]
- Low pressure loss (70 to 200 Pa), therefore energy-saving operation
- Low sound power level
- Heating also possible without primary air, which saves energy when heating at night and at weekends
- Heat exchanger cleanable from the front and the rear (in compliance with requirements of VDI 6022). The large fin spacing enables easy cleaning and obviates the need for a filter.
- Suitable for new or refurbished buildings (for replacing high-pressure induction units)
- Condensate tank below heat exchanger, inclusive of drain with ½" connector

Graph 7: Sound power level and primary air-side pressure loss

Type code

IG – Q – SB – ____ – ____
 Induction unit – Displacement ventilation – Placement – Nominal unit width – Secondary air intake

Placement:
 SB = vertical parapet mounting
Nominal unit width
 800, 1000 and 1200
Secondary air intake
 V = at the front
 O = at the top

Tender text

..... units

Induction unit for displacement ventilation – for vertical parapet mounting – for cooling, heating, and fresh air supply along the building facade through window parapets.

Unit to be integrated into the existing parapet cover, with primary air connection and built-in metallic primary air nozzles, consisting of:

- water heat exchanger made from copper piping with aluminium fins and separate circuits for heating and cooling; large fin spacing for easy cleaning as per VDI 6022;
- condensate tank inclusive of drain with ½" connector;
- primary air box with inspection opening as per VDI 6022;
- displacement air outlet for discharging supply air – made up of a blend of primary and secondary air – at low turbulence and low momentum, according to the principle of displacement ventilation.

Primary air connection (as seen from the unit front)

- on the left on the right,
- water connection on the right
- with control valves
- with L-fasteners for mounting the unit on the wall, adjustable in two planes.

Technical data

Primary air volume flow rate: l/s (m³/h)
 Allowable sound power level: dB(A) ref. 10⁻¹²W
 Pressure loss on air side: Pa
Cooling mode
 Total cooling output: W
 Water supply temperature: °C
 Water flow rate: l/h
 Pressure loss on water side: kPa
Heating mode
 Heating output (secondary): W
 Water supply temperature: °C
 Water flow rate: l/h
 Pressure loss on water side: kPa

Material

Housing: galvanized sheet metal
 without powder coating
 painted to RAL 9005 (jet-black)
 Heat exchanger: copper / aluminium

Dimensions

Nominal unit width ¹⁾: mm
 Depth: 160 mm
 Height: 680 mm

Allowable operating pressure of heat exchanger: 16 bars

Make: KRANTZ KOMPONENTEN

Type: IG-Q-SB-____-__

– Subject to technical alteration –

¹⁾ Consult us for other sizes