

Cooling and heating systems

Chilled beam DK-F – without ventilation function



DS 4091 E 05.2005

Preliminary remarks

Chilled beams are used for room cooling in the commercial sector, in trade and industry. They remove high cooling loads with a water system without a mechanical ventilation plant as an alternative to cooling ceilings - without, however, heat removal by radiation.

By keeping to certain layout parameters, acceptable thermal comfort conditions can be achieved with respect to indoor air velocities.

The DK-F type is a passive chilled beam without primary air supply. It operates solely through free convection. The indoor air quality must be safeguarded by means of additional mechanical ventilation or window ventilation (which affects control).

Construction design and function

The main components of the DK-F chilled beam with free convection are the open-top housing 1 (Figure 1), the built-in heat exchanger 2 with the terminals 3 and possibly a pervious underscreen 4 (in visible installation as in Figure 4 a, b or c as type DK-FS).

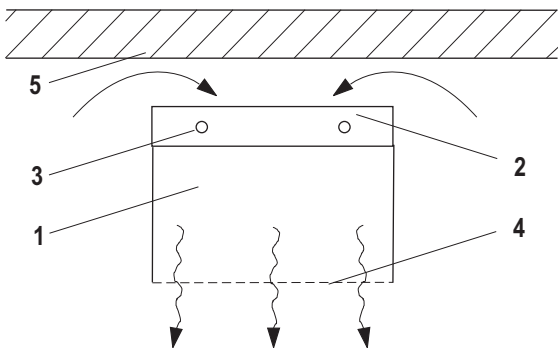

Figure 1: Structure of DK-FS chilled beam

For room cooling indoor air flows as a result of cooling in the air-water heat exchanger and the duct effect of the housing from above into the chilled beam. Depending on width, a nominal distance a_R must therefore be kept from the concrete ceiling 5 (see Table 3, page 5). Smaller distances result in impaired performance as in Graph B, page 6.

The dimensions for the standard lengths 1.2 – 3 m in intervals of 300 mm and the standard widths are shown in Figure 2 and the following table.

The standard heights amount to 180 mm and 250 mm. Due to the duct effect under the heat exchanger, the height influences cooling capacity (see Technical data and Layout).

There are several installation options for the chilled beams. These are usually suspended from the concrete ceiling using, for instance, threaded rods. The suspension points at the chilled beam are either fixed L-fasteners at the housing walls or movable brackets at the top side of the housing (see Fig. 2). Figures 4a to 4d show the most common installation options.

In the concealed installation above a pervious false ceiling there is no need for a screen on the underside of the chilled beam (see Figure 3 - type DK-FZ).

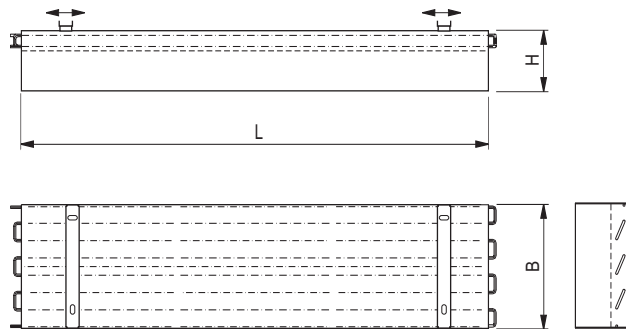

| Nominal width B in mm | Nominal height * H in mm | Nominal length * L in mm | Weight per running metre kg/m | |
|---------------------------|-----------------------------|--|----------------------------------|-------|
| | | | DK-FZ | DK-FS |
| 300 | 180 / 250 | 1200 / 1500 / | 6.7 | 8.5 |
| 400 | | 1800 / 2100 / | 7.8 | 9.7 |
| 500 | | 2400 / 2700 / | 8.8 | 10.8 |
| 600 | | 3000 | 9.9 | 12 |
| Standard colour: | | RAL 9010 / RAL 9011 or unpainted | | |
| Water connection options: | | Endwise Ø12 and 15 mm (depending on water volume flow rate) Sleeve Rp ½ or calibrated pipe terminal for plug connection systems | | |
| Suspension: | | Concealed or visible using threaded rods | | |

* Other lengths and heights also available as required

Figure 2: Standard dimensions and constructions

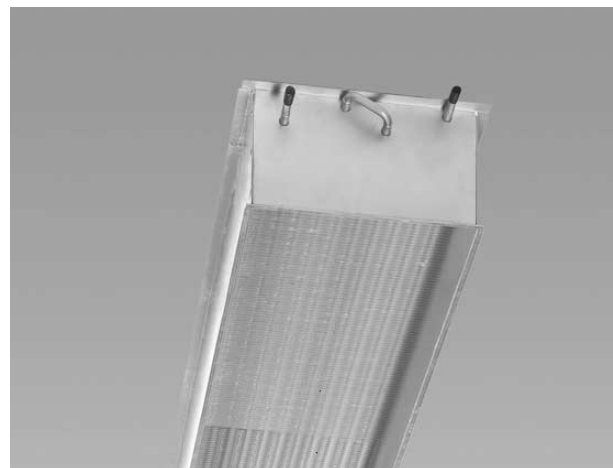

Figure 3: Installation of DK-FZ chilled beam above a pervious false ceiling

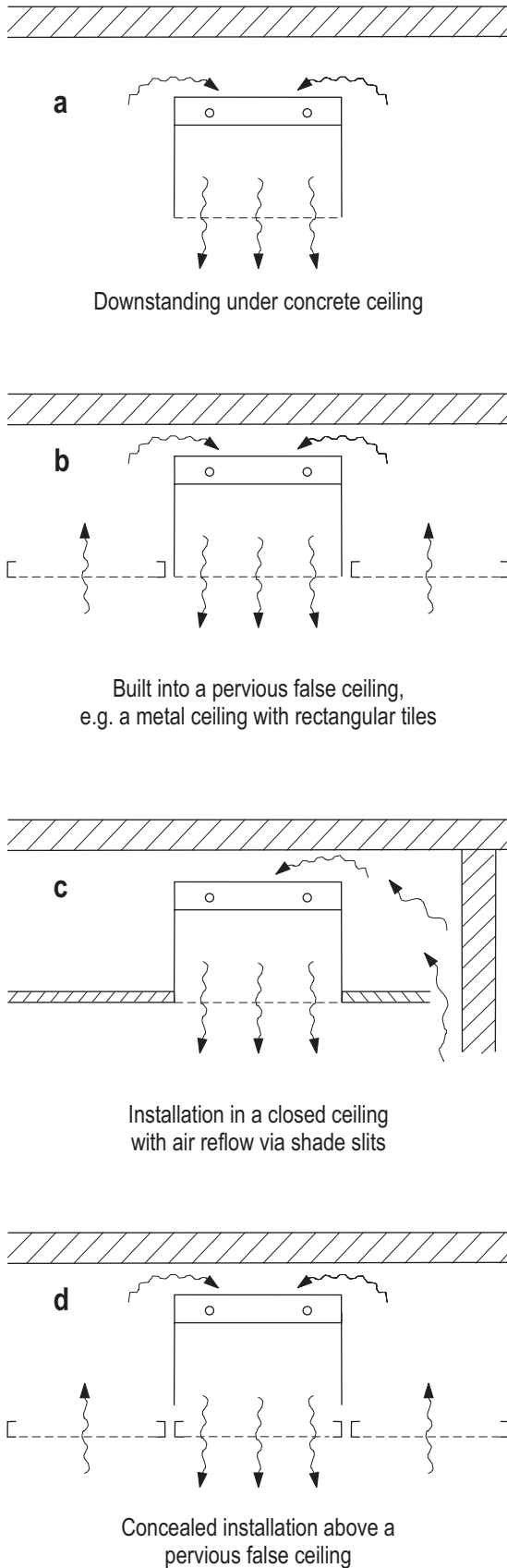

Figure 4a - 4d: Installation options of chilled beams

Planning specifications

Placement and thermal comfort

The anticipated indoor air velocity under the passive chilled beams is decisive for their placement in relation to the workplaces in the room. Since heat removal is effected almost solely by convection, rising velocities can be expected with increasing specific cooling capacity - Figure 5 shows a typical flow pattern. We therefore recommend not placing this type of chilled beam above permanent workplaces.

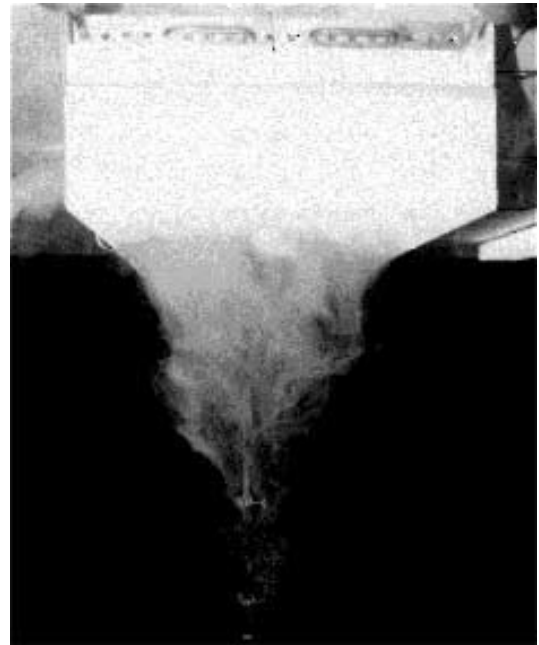

Figure 5: Typical flow pattern under a passive chilled beam

A suitable arrangement for offices is the installation at the facade or near the corridor wall as in Figures 6 or 7. This avoids draughts at head level so that a higher cooling capacity can be chosen for the same thermal comfort at the workplace. As shown in Figure 7, a stable indoor air flow is generated in the form of a tangential air pattern with buoyancy at the facade (in summer with solar irradiation, in winter with radiators) and downflow at the corridor wall.

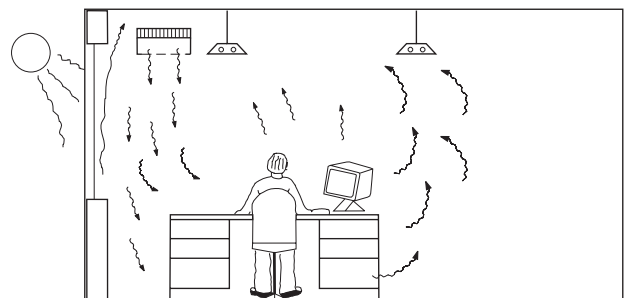

Figure 6: Chilled beam at the facade

Placing a cupboard under the beam need not impair capacity, if the distance to the bottom edge of the beam corresponds at least to beam width. If similar to Figure 7, the beam ends directly at a wall, the ceiling spacing must be twice as large in compliance with Table 3 to compensate for the disadvantage of one-sided reflow.

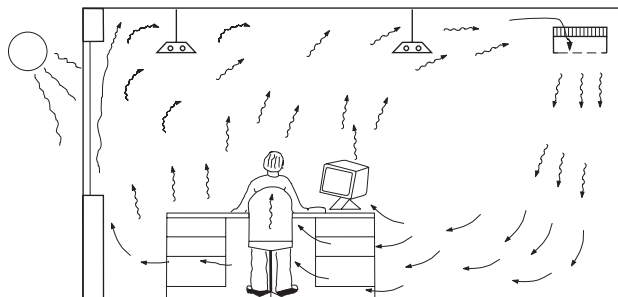

Figure 7: Chilled beam at or near the corridor wall

Preventing drop below dew-point

The dewpoint temperature of the indoor air must always be lower than the surface temperature of the chilled beam supply pipe. Condensation can be reliably avoided by following this basic rule. For greater certainty we recommend dewpoint detectors. These are fitted at the coldest and most suitable place on the cold water supply line. These signal the start of local condensation at an early stage and trigger an increase in supply water temperature or a chilled water supply shutoff, for example.

If chilled beams operate in combination with a central air handling system a sufficient dehumidification is usually ensured by the cooling coil, so that dewpoint temperature stays below the recommended supply temperature of 16°C.

If the building has openable windows, care must be taken to ensure that the dewpoint temperature of the outside air can stay over 16°C under corresponding weather conditions.

For more details please read our publication DS 4076 - Cooling ceiling system description, Register 1.2.

Technical data and layout

The cooling capacity was measured for different dimensions, constructions and installation options in line with DIN 4715.

As a reference quantity for the technical layout and for determining cooling capacity for altered constructions, the cooling capacity of a DK-F with a width of $B = 600$ mm and a height of $H = 250$ mm has been selected for a distance to the concrete ceiling of $a_R = 150$ mm. The standard cooling capacity for this amounts to 390 W/m (see Graph A, page 6).

The main determinants of the capacity of chilled beams are shown in Figure 8.

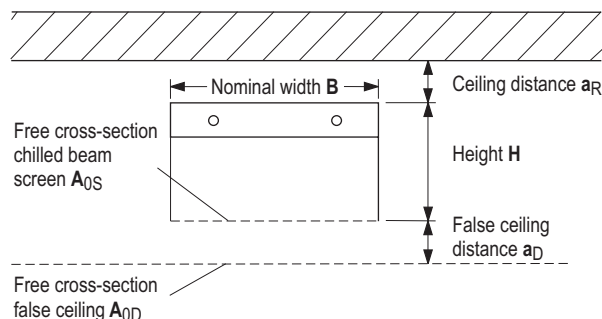

Figure 8: Major geometric parameters for cooling capacity

The actual cooling capacity under project-specific installation conditions is computed using the equation

$$\dot{q} = \dot{q}_0 \cdot k_B \cdot k_H \cdot k_a \cdot k_S \quad (1)$$

Where:

- \dot{q}_0 Specific cooling capacity from Graph A, p. 6 in W/m
- k_B Correction factor for width B from Table 1, p. 5
- k_H Correction factor for height H from Table 2, p. 5
- k_a Correction factor for the influence of the distance a_R to the concrete ceiling from Graph B, p. 6, if the nominal distance is shorter than required by Table 3
- k_S Correction factor for the influence of the free cross-section of the screen in type DK-FS as in Graph C, p. 6
- k_D Correction factor for the influence of the free cross-section of the false ceiling in type DK-FZ as in Graph D, p. 7

Table 1: Correction factor k_B for the influence of nominal width B on cooling capacity

| Nominal width B in mm | Correction factor k_B |
|-----------------------|-------------------------|
| 600 | 1.00 |
| 500 | 0.88 |
| 400 | 0.73 |
| 300 | 0.54 |

Table 2: Correction factor k_H for the influence of height H on cooling capacity

| Height H in mm | Correction factor k_H |
|----------------|-------------------------|
| 250 | 1.00 |
| 180 | 0.87 |

Table 3: Nominal distance a_R between top edge of chilled beam and concrete ceiling (for $a_R \geq$ nominal distance is $k_a = 1$)

| Nominal width B in mm | Minimum distance a_R in mm |
|-----------------------|------------------------------|
| 300 | 75 |
| 400 | 100 |
| 500 | 125 |
| 600 | 150 |

A smaller nominal distance than that indicated in Table 3 results in an obstruction of the inflow and impaired performance. This is accounted for in equation (1) by the correction factor k_a from Graph B, p. 6.

Screens with type DK-FS

In installations as in Figures 4a to c, i.e. visible underside of the chilled beam, this is constructed as a pervious screen as wide open as possible. Standard options are perforated metal sheets with a free cross-section of $A_{OS} = 40$ or 63 % or rib mesh with $A_{OS} \geq 60$ %. For special design requirements other constructions are possible on request.

For perforated metal sheets with bores > 3 mm, the correction factor k_S can be estimated with the help of Graph C, p. 6.

False ceilings with type DK-FZ

The installation option as in Figure 4d – passive chilled beams above an open, pervious false ceiling – is often chosen. The free cross-section of the false ceiling A_{OD} and its construction, e.g. with micro-perforation or grid ceiling, influence the decrease in performance. The correction factor k_D in equation (1) is determined with the help of Graph D, p. 7. The graph applies for an occupation density of the open ceiling with chilled beams of < 35 %.

With this installation option as well, the influence of the distance to the concrete ceiling (or large-surface fittings, e.g. ventilation ducts) a_R must be taken into account. The distance a_D between the bottom edge of the chilled beam and the level of the false ceiling should be at least 20 mm + height of ceiling strapping (about 50 mm).

Water volume flow rate and pressure loss

The requisite water volume flow rate is obtained from the cooling capacity and the desired spread between supply and return temperature.

Minimum permissible water volume flow rate is 80 l/h per chilled beam.

At low volume flow rates the heat transfer in the pipe declines sharply as does cooling capacity.

The water-side pressure loss is determined in the layout by KRANTZ KOMPONENTEN. It amounts as a rule to < 25 kPa.

Features

- Compact construction design
- High specific cooling capacity
- Principle of 'silent cooling'
- Various installation options
- Easy installation
- Well suited for retrofitting

Layout example

for a DK-FZ type chilled beam

The passive chilled beams are intended for a room of approx. 25 m² above a false ceiling made of perforated metal coffers with A_{OD} = 30 %. A cooling capacity of 1500 W (equivalent to about 60 W/m²-of ceiling area) is required.

The specified layout parameters are:

Supply water temperature: 16°C
Return water temperature: 18°C
Room temperature: 26°C

The false ceiling plenum has a clearance height of 400 mm. For structural reasons, the nominal width may not exceed 500 mm.

The following selections are made: B = 500 mm
H = 180 mm

(for B = 500 mm spacing amounts to a_R ≥ 125 mm, approx. ≥ 70 mm is needed between the chilled beam and the false ceiling, so the height of 250 mm cannot be used)

From Graph A: $\dot{q}_0 = 340 \text{ W}$
From Table 1: $k_B = 0.88$
From Table 2: $k_H = 0.87$
From Table 3: $k_a = 1.00$
From Table D: $k_D = 0.85$

With equation 1 we obtain:

$$\begin{aligned} \dot{q} &= \dot{q}_0 \cdot k_B \cdot k_H \cdot k_a \cdot k_s \\ \dot{q} &= 340 \cdot 0.88 \cdot 0.87 \cdot 1.0 \cdot 0.85 \\ \dot{q} &\approx 221 \text{ W/m} \end{aligned}$$

For 1500 W, 6.88 m are therefore required. Three units à 2.4 m are selected.

Installed cooling capacity then amounts to:

$$\begin{aligned} \text{Per DK-FZ:} &= 2.4 \cdot 221 = 530 \text{ W} \\ \text{and a total} &= 3 \cdot 530 = 1590 \text{ W} > 1500 \text{ W} \end{aligned}$$

Water volume flow rate, with the help of Graph E, p. 7, for 2 K → $\dot{V} = 225 \text{ l/h}$.

The water-side pressure loss for this size then amounts to 6.0 kPa.

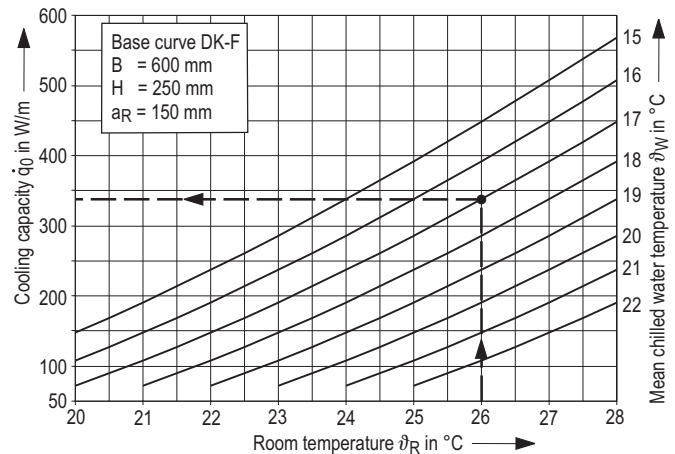

Graph A: Specific cooling capacity of a downstanding chilled beam (see Figure 1) without screen

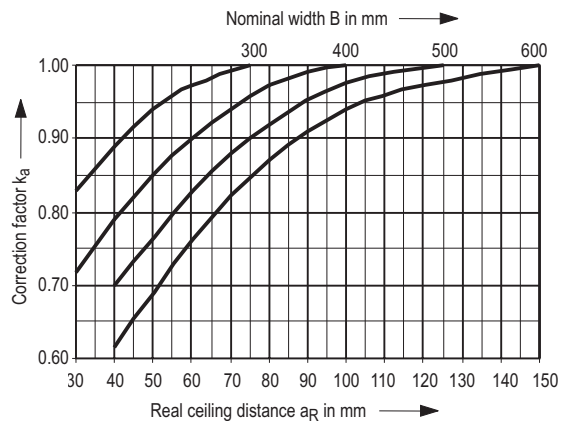

Graph B: Correction factor for the influence of the ceiling distance, when $a_R <$ nominal distance as in Table 3, p. 5.

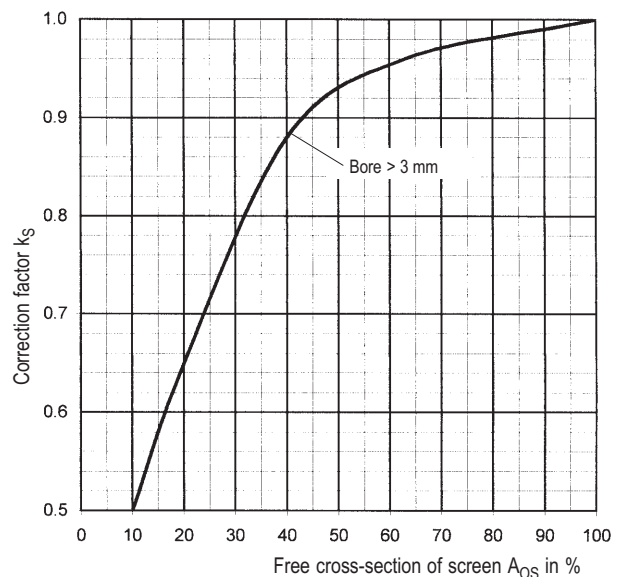

Graph C: Correction factor for the influence of a screen on cooling capacity, for type DK-FS

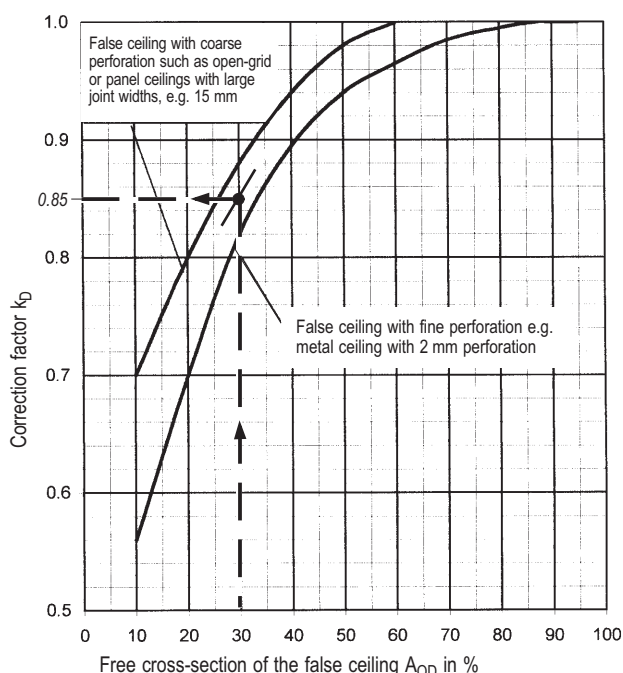

Graph D: Correction factor for the influence of a false ceiling on cooling capacity for type DK-FZ

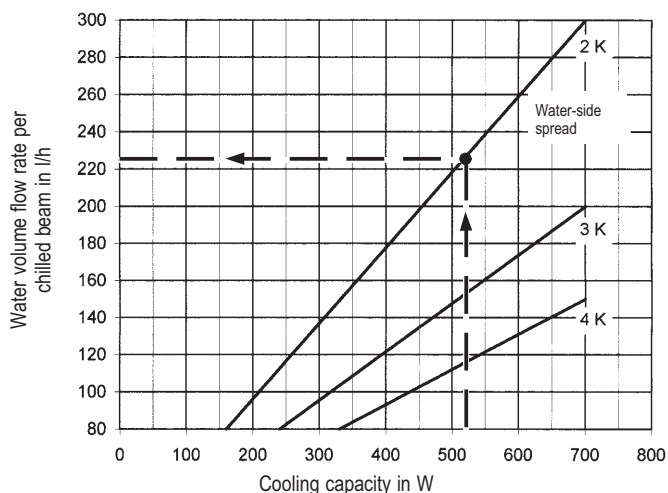

Graph E: Water volume flow rate of a chilled beam in correlation with cooling capacity and cold water temperature difference

Tender text

Type DK-FZ chilled beam

Chilled beam with high specific cooling capacity through free convection in compact form for easy installation above open false ceilings, consisting of:

- Water-air heat exchanger with horizontal copper piping and fit-on vertical aluminium blades
- Housing to accommodate heat exchanger made of galvanized sheet steel with vertical side walls
- Fastening points at top side of housing for hanging chilled beam

All visible parts powder-coated or wet-primed.

Technical data:

| | |
|--|----------------|
| Spec. cooling capacity: |W/m |
| Supply water temperature: | °C |
| Return water temperature: | °C |
| Cold water volume flow rate: | l/h |
| Room temperature: | °C |
| Free cross-section of suspended ceiling: | % |
| Pressure loss: | kPa |
| Max. operating pressure: | Standard 6 bar |
| Water quality: | Mains water |
| Dimensions / Construction: | |
| Nominal length: | mm |
| Nominal width: | mm |
| Nominal height: | mm |

Cold water connection (one-sided):

- Smooth pipe terminal Ø12, 15 mm
- Sleeve Rp 1/2
- Calibrated pipe terminal D_a = 12, 15 mm

Colour:

- Similar to RAL 9011, black (standard)
- Unpainted
- Desired colour to RAL

Number of chilled beams: units

Make: KRANTZ KOMPONENTEN

Type: DK-FZ

Tender text

Type DK-FS chilled beam

Chilled beam with high specific cooling capacity through free convection in compact form for easy visible installation in ceiling, consisting of:

- Water-air heat exchanger with horizontal copper piping and fit-on vertical aluminium blades
- Housing to accommodate heat exchanger made of galvanized sheet steel with vertical side walls and perforated screen as bottom
- Fastening points at top side of housing for hanging chilled beam

All visible parts powder-coated or wet-primed.

Technical data:

Spec. cooling capacity: W/m
(for downstanding placement)

Supply water temperature: °C

Return water temperature: °C

Cold water volume flow rate: l/h

Room temperature: °C

Pressure loss: kPa

Max. operating pressure: Standard 6 bar

Water quality: Mains water

Dimensions / Construction:

Nominal length:mm

Nominal width:mm

Nominal height:mm

Cold water connection (one-sided):

- Smooth pipe terminal Ø12, 15 mm
- Sleeve Rp ½
- Calibrated pipe terminal D_a = 12, 15 mm

Colour:

- Similar to RAL 9010, white (standard)
- Desired colour to RAL

Construction of screen:

- Perforated metal sheet A_{0S} = 63 % (standard)
- Perforated metal sheet A_{0S} = 40 %
- Rib mesh A_{0S} ≥ 60 %
- Special request

Number of chilled beams: units

Make: KRANTZ KOMPONENTEN

Type: DK-FS

- Subject to technical alterations -