

Technical Selection



Seat displacement outlet Q-St...

Preliminary remarks

Seat displacement outlets are used to supply air in rooms with fixed seating, such as auditoriums, congress halls, theatres, etc. They operate according to the displacement ventilation principle and are integrated into the seat leg.

Construction

The upper part of the single cylindrical seat leg **1** is designed in the form of a perforated metal cylinder **2**. It contains the distribution unit **3** and at the intake in the lower part the perforated orifice **4**. Depending on the type of mounting chosen, the seat leg can be screwed into the floor with a flange **5** (screw mounting) or inserted with a spigot **6** (insertion mounting).

The seat displacement outlet is available in the sizes DN 100, DN 127 and DN 190.

Key

- | | |
|--|--------------------------------------|
| 1 Seat leg with displacement outlet | 6 Spigot |
| 2 Perforated metal cylinder | 7 Thin floor (e.g. wood) |
| 3 Distribution unit | 8 Thick floor (e.g. concrete) |
| 4 Orifice | 9 Pressurized plenum |
| 5 Flange | 10 Supply air |

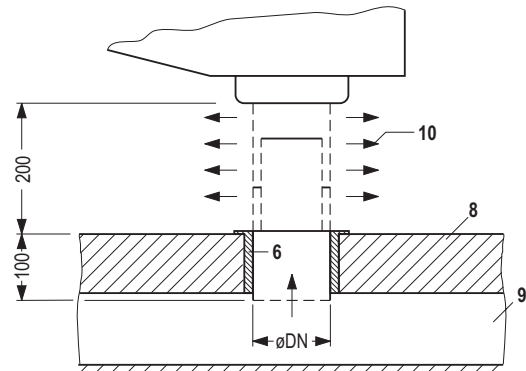
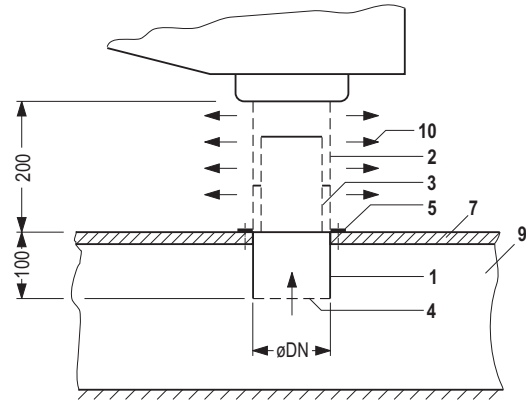

Figure 1: Seat displacement outlet, construction and dimensions

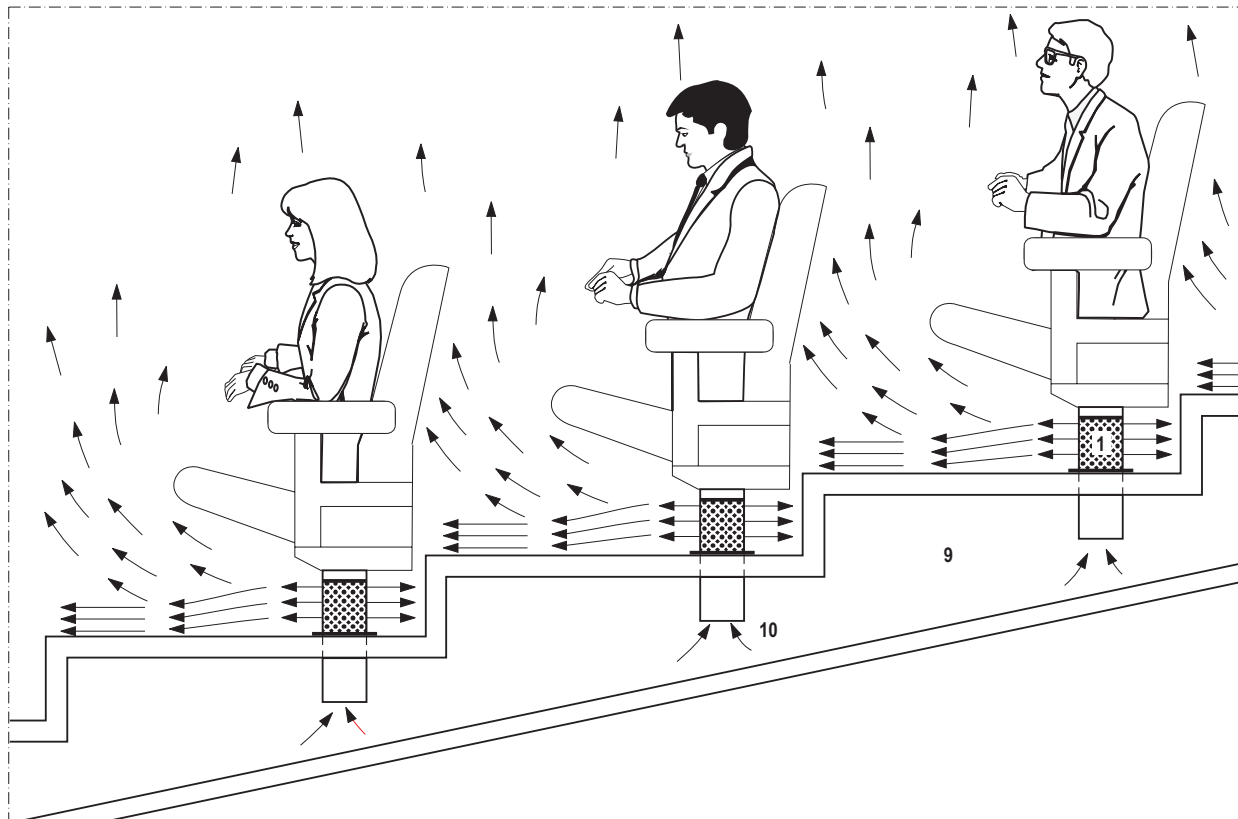

Figure 2: Air flow pattern at a seat displacement outlet

Mode of operation

The supply air flows from the floor plenum (pressurized plenum 9) via the orifice 4 into the outlet. The orifice 4 ensures an equal supply to all the seat displacement outlets connected to the pressurized plenum. Thanks to a distributor 3 an even radial air flow enters the perforated metal cylinder 2 and is discharged at low turbulence and momentum in all directions. At low velocity the supply air flows in a thin layer along the floor and rises due to buoyancy to the seated person's breathing space.

Figure 3 for example shows the discharge velocities in the near zone of the outlet for size DN 127 and supply air volume flow rate $\dot{V} = 11 \text{ l/s}$ ($40 \text{ m}^3/\text{h}$). The distance between the central axes of two outlets in Figure 3 is 550 mm, in line with the possible minimum distance between seats. At greater distances, the air velocities are even lower.

At over 500 mm above the floor, the air velocity drops to $\leq 0.1 \text{ m/s}$.

Figure 3 also shows the vertical increase in air temperature. Owing to the buoyancy flow at the seated persons, the rising air develops a vertical temperature gradient which can reach up to 2 K/m , depending on the cooling load and height of the room. The exhaust air temperature under the ceiling is therefore much higher

than the room temperature in the breathing space of the seated person. The heat load of the occupants and the lighting can thus be effectively removed with even small temperature differences between supply air and indoor air ($\Delta\vartheta \leq -4 \text{ K}$).



Figure 4: Seat displacement outlet, photograph

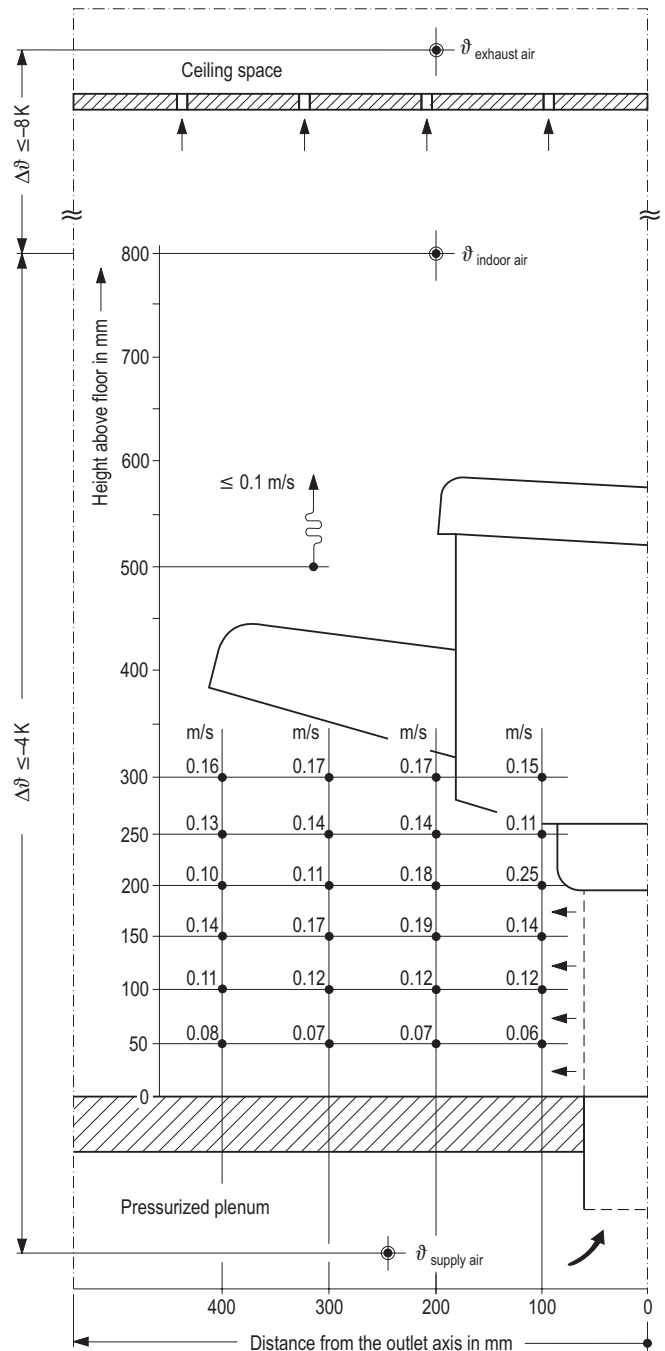
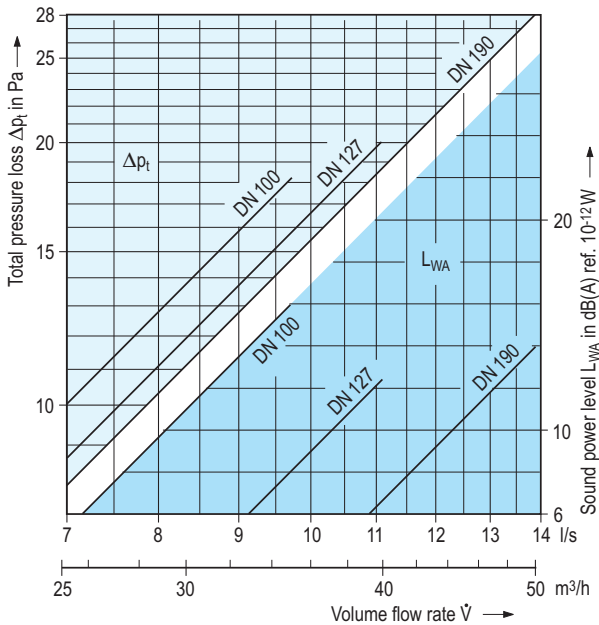

Figure 3: Example of air velocities around the feet and legs of the seated person and vertical temperature differences; size DN 127; supply air volume flow rate $\dot{V} = 11 \text{ l/s}$ ($40 \text{ m}^3/\text{h}$).

Sound power level and pressure loss



Type code

Q - St - DN - -

Displacement outlet
Kind / Funktion
Size
Type of connection

Kind / Function

St = seat displacement outlet

Size

DN 100, DN 127,
DN 190

Type of connection

F = connection flange for screw mounting
R = spigot for insertion mounting

Tender text

..... Units

Seat displacement outlet, integrated in the seat leg for draught-free fresh air supply in the occupied zone, consisting of:

perforated metal cylinder (seat leg) with orifice at the supply side for even air supply to all outlets connected to a pressurized plenum and built-in air distribution unit for even distribution on the inside of the perforated metal cylinder.

Floor connection with

flange mounting, insertion mounting with spigot,

Seat displacement outlet made of galvanized steel,

Painting of the visible part of the outlet to

RAL

Technical data

Volume flow rate: l/s (m^3/h)

Perm. sound power level: dB(A) ref. 10^{-12} W

Pressure loss: Pa

Nominal diameter: DN

Outlet height²⁾: 200 mm

Make: KRANTZ KOMponenten

Type: Q-St-DN ____-__

Subject to technical alterations!

Layout data

Size		DN 100	DN 127	DN 190
Supply air volume flow rate \dot{V}	l/s	10	11	14
	m^3/h	35	40	50
Air outlet height	mm	200		
Discharge velocity	m/s	≤ 0.16		
Supply air temperature	$^{\circ}C$	≥ 20		
Temperature difference supply air - indoor air ¹⁾	K	≤ -4		
Temperature difference supply air - exhaust air	K	≤ -12		

Features

- Air distribution system for auditoriums, congress halls, theatres and other assembly rooms with fixed seating
- Integrated into the seat leg
- Low turbulence, horizontal, radial jet distribution over the floor
- Draught-free fresh air supply in the occupied zone
- Connection to the pressurized plenum
- Very low sound power level ($L_{WA} \leq 16$ dB(A) ref. 10^{-12} W)
- Available in three sizes
- Outlet volume flow rate 14 l/s ($50 m^3/h$)
- Temperature difference between supply air and indoor air up to -4 K and between supply air and exhaust air up to -12 K, depending on the room cooling load and height

1) At head height of seated person

2) Installation and construction details in consultation with the seat manufacturer