

Swivel displacement outlet VA-S....

Swivel displacement outlet

Construction design and function

Preliminary remarks

Displacement air outlets are used to efficiently remove dust particles and air pollutants from production and work areas. The supply air should be discharged near the occupied zone to keep the pollutant load as low as possible. For constructional or operational reasons it is not always possible to place the air outlets near the occupied zone. For these applications or for the removal of air pollutants from large work areas KRANTZ KOMPONENTEN has developed the swivel displacement outlet.

Construction design and function

The main components are the housing **1** with the duct connection flange **2** and the built-in swivel air distribution element **3**. Depending on the desired direction of air flow and jet penetration depth, the air distribution element can be swivelled from +10° to -35° to the horizontal. At the maximum cooling load the air is discharged with a jet direction of +10° and at the maximum heating load with a jet direction of -35°. The direction of air flow can be altered manually or with the aid of a servomotor **6**, which can be positioned on the right or left side of the outlet housing.

The large front panel of the air distribution element consists of a perforated plate **4** with 3 to 6 built-in twist outlets **5**, depending on the length of the displacement outlet. The perforated plate generates a low-turbulence air flow which is partially induced and generally stabilized by the jet momentum from the twist outlets.

In penetration depth, a distinction is made between primary penetration depth L_{prim} and maximum supply air penetration depth L_{max} . In the cooling mode, the primary penetration depth denotes the distance to the swivel displacement outlet at which the supply air completely enters the occupied zone. The subsequent zone is supplied by a horizontal flow parallel to the floor. The resultant maximum supply air penetration depth is about 50% greater than the primary penetration depth.

When heating, the primary penetration depth designates the distance to the swivel displacement outlet at which partial flows of supply air begin to ascend. Here too, the maximum supply air penetration depth can be set higher by a factor of 1.5 (see page 3 for the air flow pattern when cooling and heating).

Depending on the applications several displacement outlets may be mounted in series to a supply air duct. The duct surface should be as smooth as possible (without beads or seams).

The outlet housing and perforated plate are made of galvanized sheet metal, the twist outlets of polystyrene.

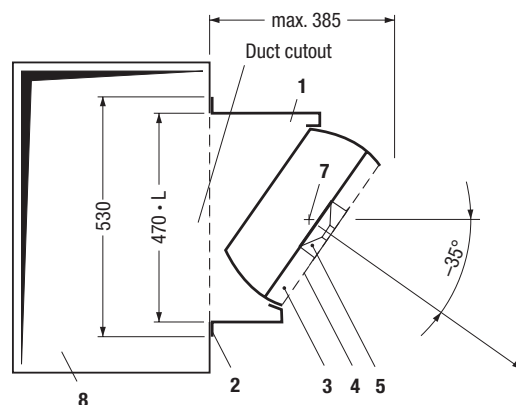
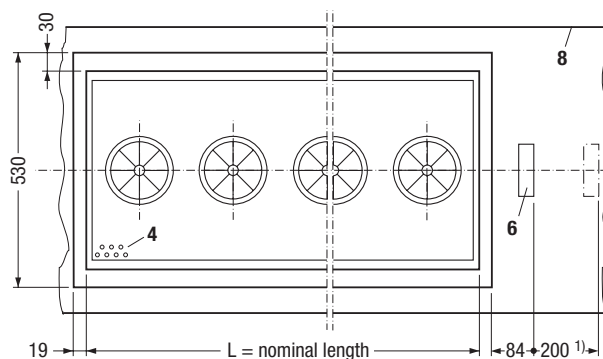

Max. heating load: direction of air jet -35°

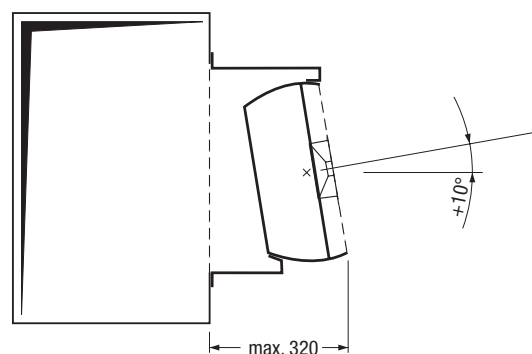

Max. cooling load: direction of air jet +10°

Key

- 1 Housing
- 2 Connection flange
- 3 Air distribution element
- 4 Perforated plate
- 5 Twist outlet
- 6 Servomotor
- 7 Swivel point
- 8 Supply air duct

Nominal length L mm	Volume flow rate		Number of twist outlets units	Weight G kg
	\dot{V} l/s	\dot{V} m ³ /h		
1,200	260 – 600	960 – 2,160	3	36
1,600	350 – 800	1,280 – 2,880	4	44
2,000	440 – 1,000	1,600 – 3,600	5	56
2,400	530 – 1,200	1,920 – 4,320	6	65

¹⁾ Minimum clearance for motor removal

Swivel displacement outlet

Layout

Layout

The outlet layout will be made using the graphs below.

The limit values for indoor air velocities to German guideline VDI 3802 'Air conditioning systems for factories' are to be kept to. Therefore, the following maximum specific volume flow rates should not be exceeded:

Activity level II	
Light activity while standing	280 l/(s·m) [1,000 m ³ /(h·m)]
Activity level III	
Moderate activity while standing	390 l/(s·m) [1,400 m ³ /(h·m)]
Activity level IV	
Heavy activity while standing	500 l/(s·m) [1,800 m ³ /(h·m)]
Horizontal penetration depths:	
- Cooling, L _{prim}	6 to 15 m
- Heating, L _{prim}	3 to 15 m
Discharge height:	
Max. temperature difference between supply air and indoor air:	±8 K

Sound power level and pressure drop

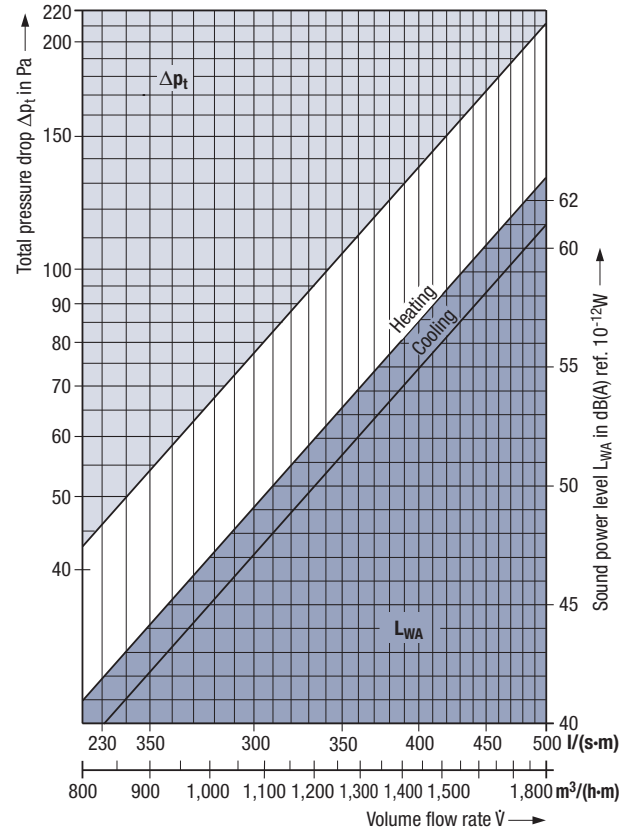

Sound power level and pressure drop

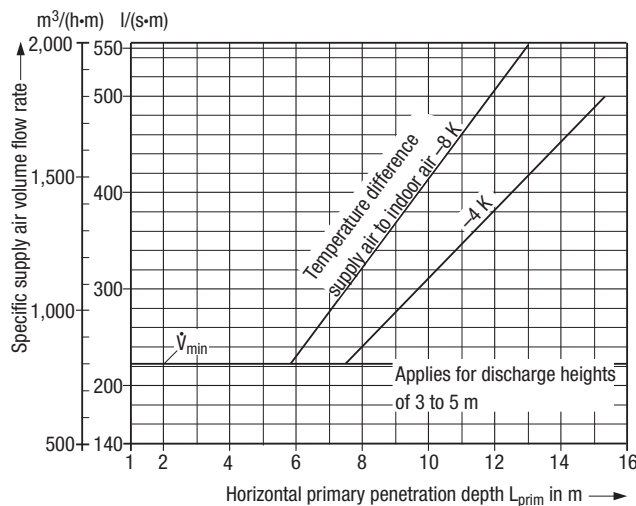
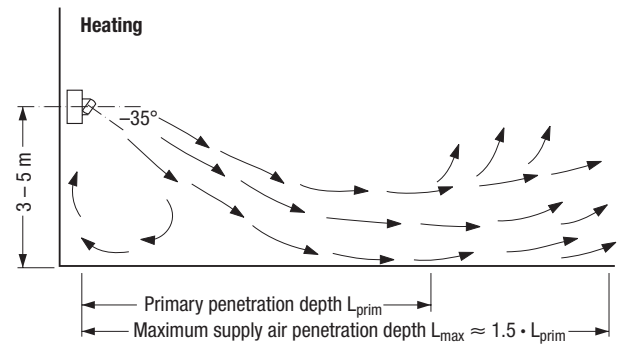
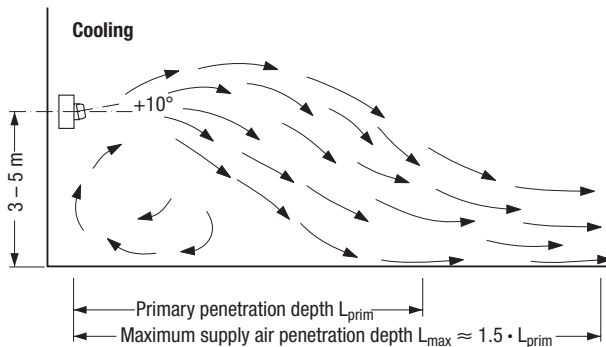

Jet penetration depth when cooling

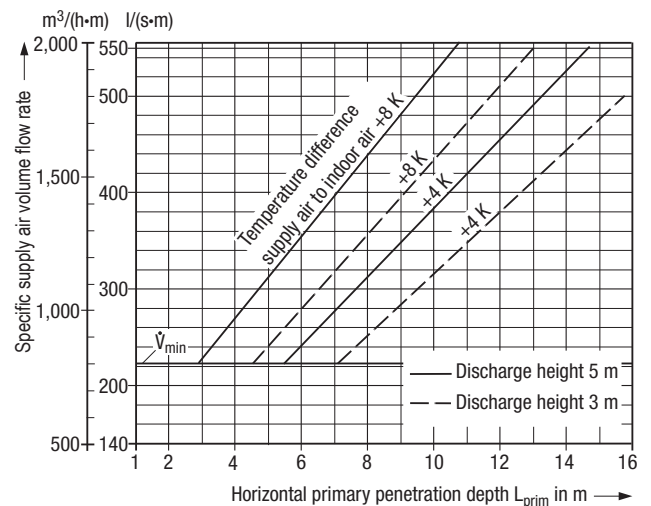

Jet penetration depth when heating

Swivel displacement outlet

Features, type code, tender text

Features

- Low-turbulence displacement flow
- High fresh air quality in the occupied zone
- Placement above the occupied zone, discharge height 3 to 5 m
- Well suited for cooling and heating thanks to stepless adjustment of discharge direction by swivel air distribution element
- Adjustment manually or with servomotor
- Primary penetration depth of supply air jets up to approx. 15 m, max. supply air penetration depth about 20 m
- Max. temperature difference supply air to indoor air ± 8 K
- Volume flow rate range of 260 to 1,200 l/s [960 to 4,320 m³/h]
- 4 nominal lengths from 1,200 to 2,400 mm
- Housing and perforated plate made of galvanized sheet metal and twist outlets of polystyrene
- Connection to rectangular ducts to EN 1505
- Robust construction with few adjustable parts

Tender text

..... units

Swivel displacement outlet with low induction effect and minimal mixing of supply air with indoor air for optimum displacement of dust particles and pollutants from the occupied zone,

consisting of:

- housing for duct connection, built-in swivel air distribution element with large front panel made up of a perforated plate and built-in twist outlets,
- swivel mechanism to change the direction of air flow from +10° to -35° to the horizontal, positioned to the right or left of the housing (related to air flow); adjustment options: manual device or electric servomotor.

Type code



Nominal length

- 1200 = Nominal length 1,200
1600 = Nominal length 1,600
2000 = Nominal length 2,000
2400 = Nominal length 2,400

Adjustment

- MA = manual
E19 = „Siemens servomotor, 0 – 10 V modulation“, rotation drive type GEB161.1E
E20 = „Siemens servomotor, 3-point type, 24 V“, rotation drive type GEB131.1E
E21 = „Siemens servomotor, 3-point type, 230 V“, rotation drive type GEB331.1E

Position of adjusting device

- R = to the right (related to air flow)
L = to the left (related to air flow)

Material:

- Housing and perforated plate made of galvanized sheet metal
- Twist outlets made of polystyrene, hardly inflammable (class B1 to DIN 4102-1)

Make:

KRANTZ KOMponentEN

Type:

VA - S - ____ - __ - __

Subject to technical alterations.