

Wall displacement outlets Q-W....



DS 4055 E 05.2010

Preliminary remarks

KRANTZ KOMPONENTEN has a broad range of displacement outlets for low-turbulence air distribution in commercial buildings. Depending on design, displacement air outlets can be mounted in a raised floor or at floor level in front of a wall or parapet, or they can be placed on the floor in room corners or niches or in front of columns. The main benefit of displacement ventilation is the high ventilation efficiency and the resulting excellent quality of air in the occupied zone. Another benefit is the low-momentum indoor air flow that flushes the room at low velocity, absolutely draught-free, thus displacing heat and air pollutants from the occupied zone to the ceiling.

It is also a great advantage to have displacement air outlets in the upper segment of a corridor wall (Fig. 2). In this case the supply air glides down the wall at low turbulence, spreads over the whole floor area and then moves upwards at the heat sources. With this system, the supply and return air ducts can be installed at low cost above the false ceiling of the corridor, thus eliminating ductwork inside the room.

For this purpose KRANTZ KOMPONENTEN supplies three types of wall displacement outlet:

- Linear wall displacement outlet
- Circular wall displacement outlet
- Combined wall displacement outlet.

The flow patterns of these 3 types are shown in Fig. 2 and 3.

With the **linear wall displacement outlet** the supply air is discharged horizontally through a rectangular perforated faceplate and is immediately deflected downwards due to gravity; it then flows down the wall to the floor.

The **circular wall displacement outlet** has a circular perforated air discharge surface with an edge towards the wall. Air discharge is both horizontal and radial (due to the edge). Radial dispersion towards the ceiling is prevented by the special outlet design. Due to the gravitational force on the cold supply air jets, the supply air flows down the wall to the floor.

The **combined wall displacement outlet** is made up of a rectangular housing and a rectangular perforated faceplate. The housing is divided into the lower supply air segment and the upper return air segment. The supply air discharge pattern is the same as with the linear type. The return air is extracted evenly through the upper segment of the faceplate.

While the linear and circular types have one connection spigot, the combined wall displacement outlet is fitted with two spigots: one for supply air and one for return air.

With the linear or circular wall displacement outlet, the return air is extracted through separate devices, e.g. extract slots or grilles, shadow gaps, pressurized ceiling plenums.

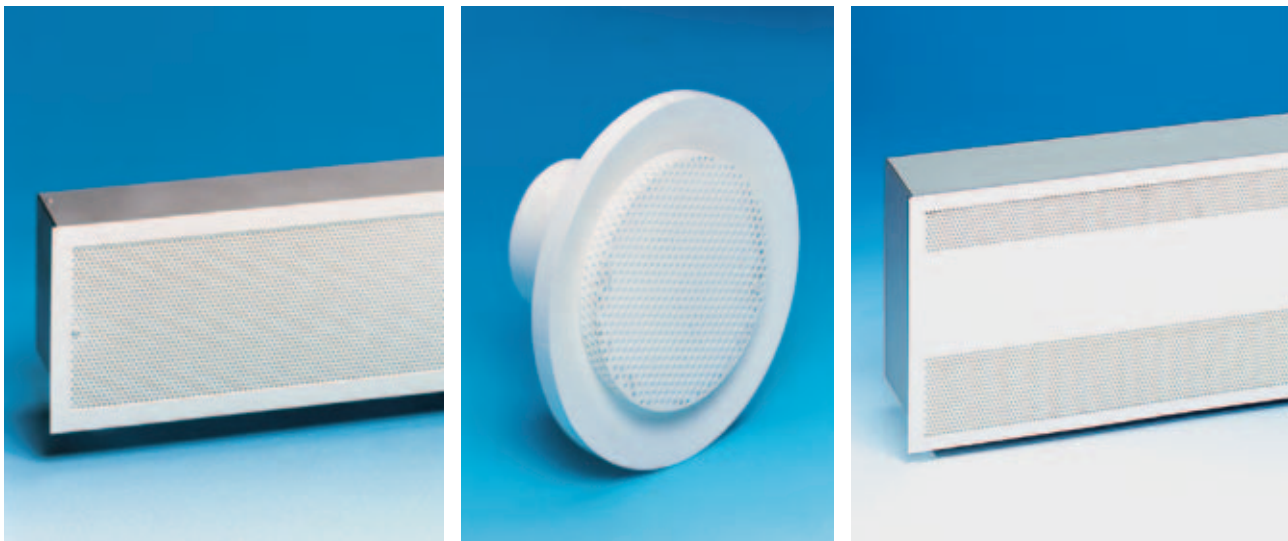
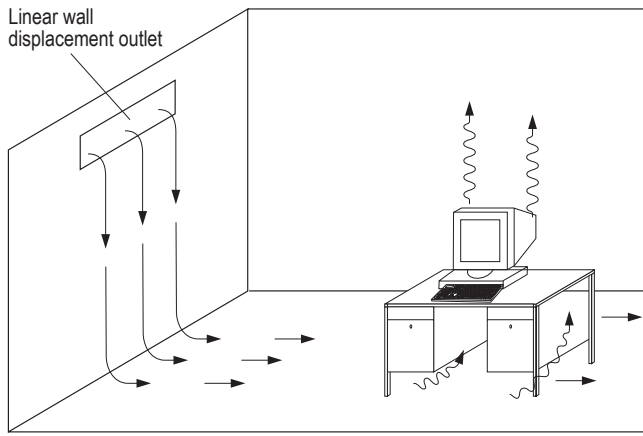

Fig. 1:

Left: Linear wall displacement outlet

Middle: Circular wall displacement outlet

Right: Combined wall displacement outlet



Q-WL

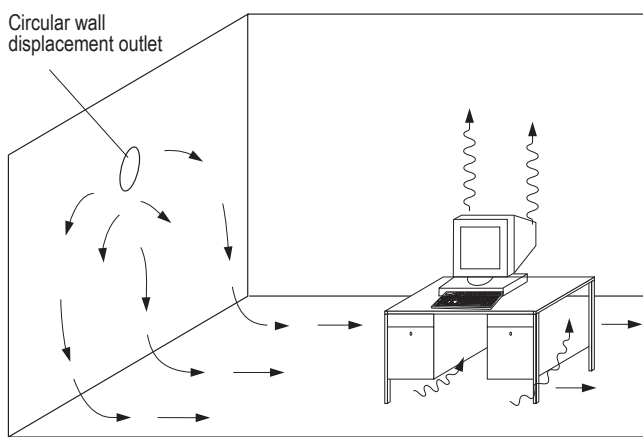
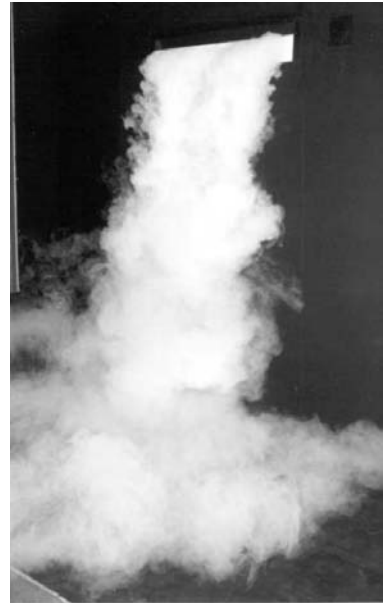

Q-WR

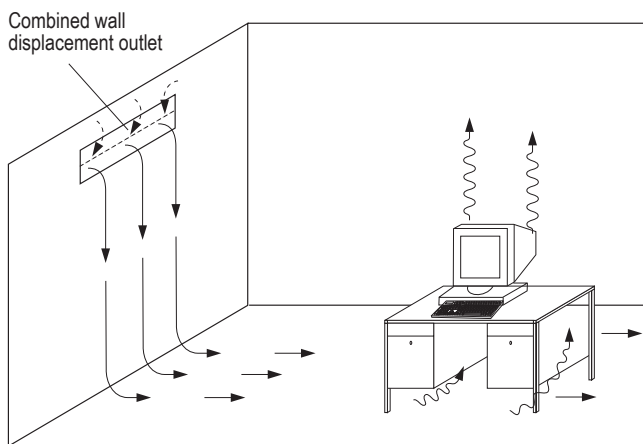

Q-WK



Fig. 2: Flow pattern

Fig. 3: Jet dispersion

Construction design and function

Linear wall displacement outlet

The main components of this air outlet (Fig. 4) are the rectangular housing **1** with round connection spigot **2**, a special jet straightener **3**, the finely perforated faceplate **4** and the air distribution plate **5**.

The jet straightener ensures an even volume flow distribution through the air discharge surface.

The perforated faceplate produces a low-turbulence displacement flow with low momentum and low induction of indoor air. The faceplate is easily detachable for cleaning.

Circular wall displacement outlet

The main components of this air outlet (Fig. 5) are the circular housing with exit flange **6**, the connection spigot **8**, the intake throttle **9** and the finely perforated faceplate **10**. Outlet fastening will be done either via claw fasteners **7** or via a lip seal **8a** at the connection spigot designed for insertion into a spiral seam duct.

The perforated faceplate produces a low-turbulence displacement flow with low momentum of the supply air jets. The faceplate is detachable for cleaning.

The exit flange has a 14 mm turn-out. On site, the client may place the outlet in a recess in the wall. The maximum recess depth is 14 mm, i.e. the exit flange can be mounted flush with the wall surface.

Combined wall displacement outlet

This air outlet (Fig. 6) mainly consists of the rectangular housing **11** with supply and return air segments **12** & **13**, an interjacent thermal partition **14**, the perforated metal sheet **15** and the finely perforated faceplate **16** which is detachable.

At the rear are the connection spigots for supply air **17** and return air **18** and the air distribution plate **19**.

The return air is extracted through the upper segment of the faceplate while the supply air is discharged downwards through the lower segment at low turbulence and very low velocity. The discharge momentum of the supply air jets is extremely low.

If required, a volume flow damper can be built into the linear or combined outlet and operated from the room side upon removal of the faceplate. It is recommended to first mount the air outlets without their faceplates which should be unpacked and installed only after commissioning of the HVAC plant. Installing the faceplates subsequently will not alter the distribution of the air volume flow rates but will preclude the risk for the faceplates to get dirty or be damaged.

With all three types, the supply air glides downwards along the free wall surface. If there are pieces of furniture against the wall, the supply air flows around them so they do not impair the air spread. Then the supply air glides at low velocity above the floor and, owing to the buoyancy forces in the room, ascends to the breathing region of the occupants. The indoor air flow at floor level is absolutely draught-free and the velocities of the displacement upflow are ≤ 0.10 m/s. The warm and stale indoor air ascends to the ceiling where it is extracted through appropriate apertures. Air spread throughout the room is ensured all the time.

Unlike in displacement ventilation from the floor, the supply air temperature here can be lowered up to 16°C, this for the reason that the descending supply air warms up sufficiently before reaching the floor level.

The maximum temperature difference between supply air and indoor air in the occupied zone may reach -6 K, that between supply air and return air -8 K. The temperature differences in the occupied zone are ≤ 1 K.

Examples of velocity and temperature distribution in the room are shown in Fig. 7 and 8. Fig. 7 applies for the linear or circular wall displacement outlet while Fig. 8 shows the combined wall displacement outlet in conjunction with a chilled ceiling.

Layout specifications

The maximum penetration depth is approx. 6 m. The mounting height is maximum 4 m (approximately) and minimum 2 m. The minimum outlet-to-ceiling distance is 120 mm.

With the linear or circular wall displacement outlet, the return air can be extracted at the side of or above the supply air outlet. If it is extracted through a linear slot placed above the wall displacement outlet at velocities > 0.6 m/s, the spacing between that slot and the outlet should be at least 80 mm.

The supply air temperature in the occupied zone should be 1 to 6 K under the room temperature. The purpose of wall displacement outlets is to supply fresh air and to remove internal heat loads. Room heating is to be provided by other equipment (e.g. static heating).

It is of course possible to combine wall displacement outlets with chilled ceilings. The return air temperature will then be nearly the same as the indoor air temperature in the occupied zone.

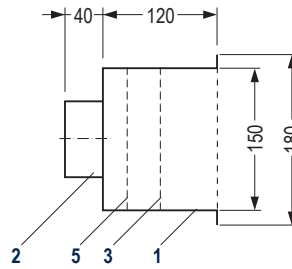
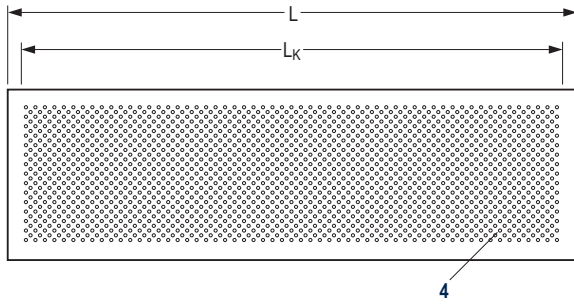

Max. volume flow rate		Nominal length	Box length	Connection spigot	Weight
l/s	m ³ /h	L mm	L _K mm	DN mm	G kg
16.5	60	600	570	80	2.9
22	80	800	770	100	3.4
28	100	1000	970	100	4.1
35	125	1200	1170	125	4.8

Fig. 4: Linear wall displacement outlet

Key for linear wall displacement outlet

- 1 Rectangular housing
- 2 Circular connection spigot
- 3 Straightener
- 4 Perforated faceplate
- 5 Air distribution plate

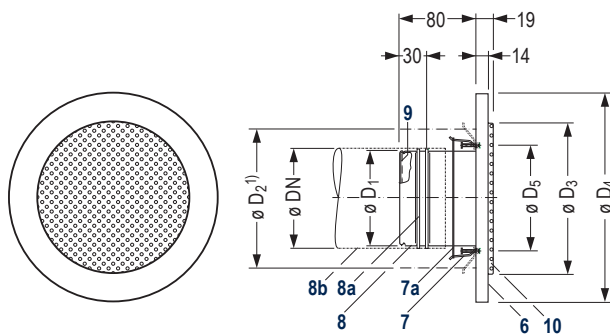

Fig. 5: Circular wall displacement outlet

Max. volume flow rate		Nom. ø						Weight
l/s	m ³ /h	DN mm	øD ₁ mm	øD ₂ ¹⁾ mm	øD ₃ mm	øD ₄ mm	øD ₅ mm	G kg
16.5	60	80	79	120	130	190	92	0.5
28	100	100	99	140	160	220	112	0.6
36	130	125	124	165	200	260	137	0.8

¹⁾ ø D₂ = wall cutout

Key for circular wall displacement outlet

- 6 Circular housing with flange
- 7 Claw fasteners
- 7a Rubber ring
- 8 Connection spigot
- 8a Lip seal (option)
- 8b Round duct
- 9 Intake throttle
- 10 Perforated faceplate

The screws at the claw fasteners 7 will be turned with an Allen key through a perforation of the faceplate.

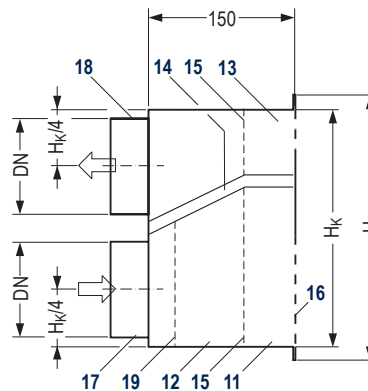
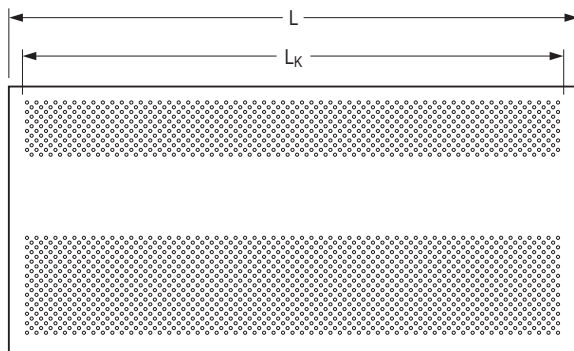

Key for combined wall displacement outlet

- 11 Rectangular housing
- 12 Supply air segment
- 13 Return air segment
- 14 Thermal partition
- 15 Perforated metal sheet
- 16 Perforated faceplate
- 17 Connection spigot, supply air
- 18 Connection spigot, return air
- 19 Air distribution plate

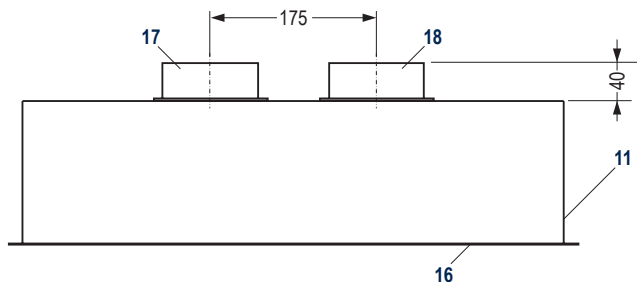

Max. volume flow rate		Nominal length		Box length		Height		Connection spigot	Weight
l/s	m ³ /h	L mm	L _K mm	H mm	H _K mm	DN mm	G kg		
16.5	60	600	570	280	250	2 x 80	4.0		
22	80	800	770	280	250	2 x 100	5.2		
28	100	1000	970	280	250	2 x 100	6.6		
35	125	1200	1170	310	280	2 x 125	9.7		

Fig. 6: Combined wall displacement outlet

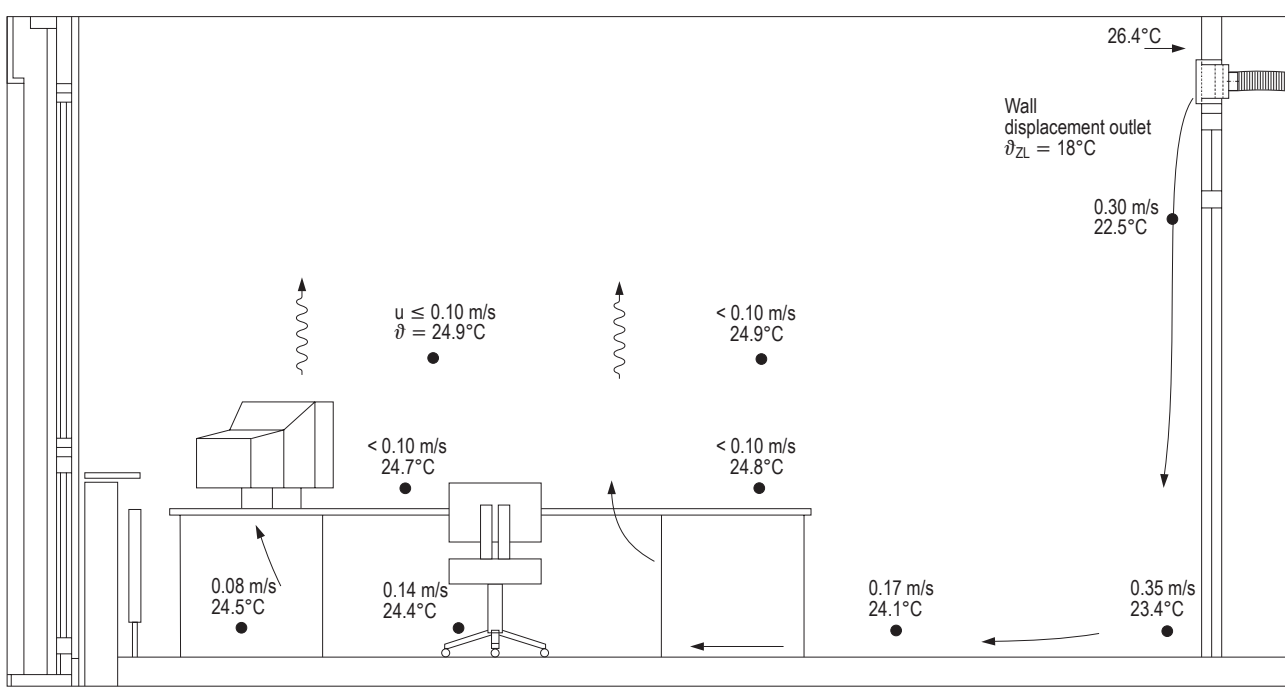

Fig. 7: Example of velocity and temperature distribution in the room with Q-WL or Q-WR

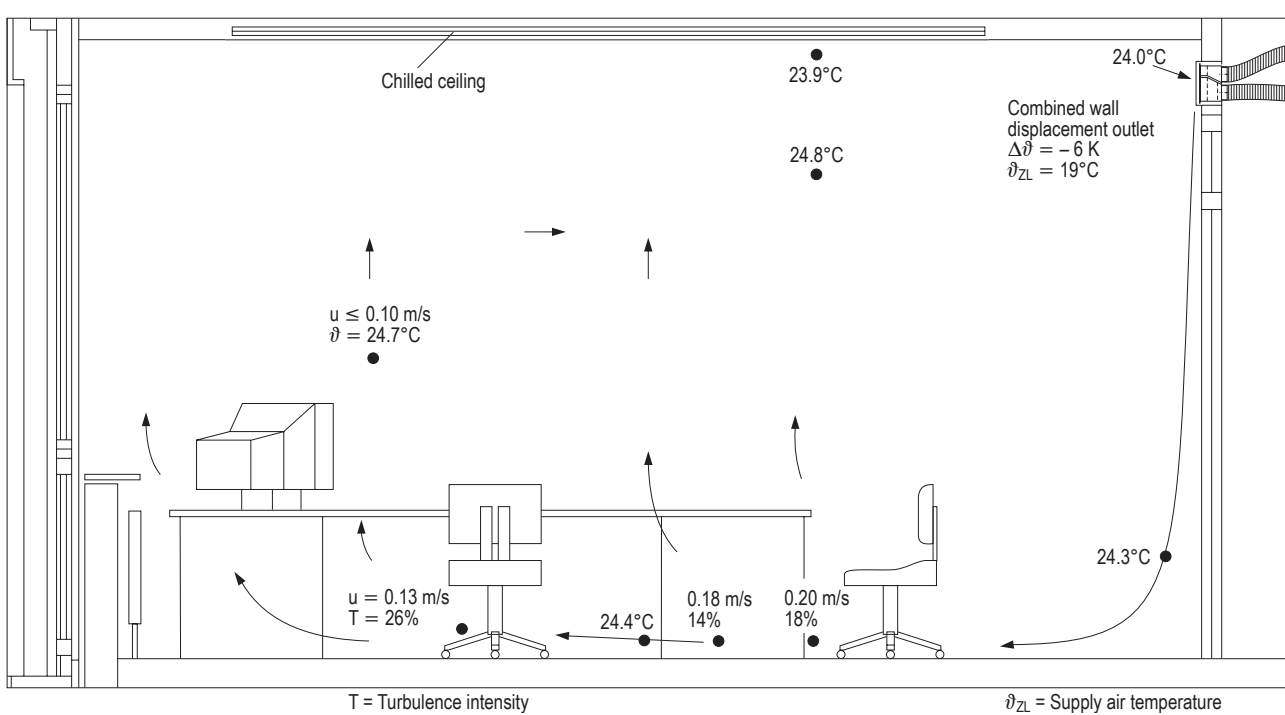

Fig. 8: Example of velocity and temperature distribution in the room with Q-WK

Sound power level and pressure drop

The sound power level is low:

- max. 33 dB(A) ref. 10^{-12} W for the linear type
- max. 34 dB(A) ref. 10^{-12} W for the circular type
- max. 32 dB(A) ref. 10^{-12} W for the combined wall displacement outlet.

The pressure drop amounts to max. 42 Pa.

Type	Insertion loss D in dB								\bar{D}
	Octave band centre frequency in Hz								
	63	125	250	500	1 K	2 K	4 K	8 K	
Q-WL (linear)	3	2	2	2	3	5	8	9	4
Q-WR (circular)	4	3	3	1	1	2	0	0	2
Q-WK (combined)									
- supply air side	3	2	2	4	5	8	7	9	5
- return air side	4	5	3	3	3	9	10	14	6

Linear wall displacement outlet

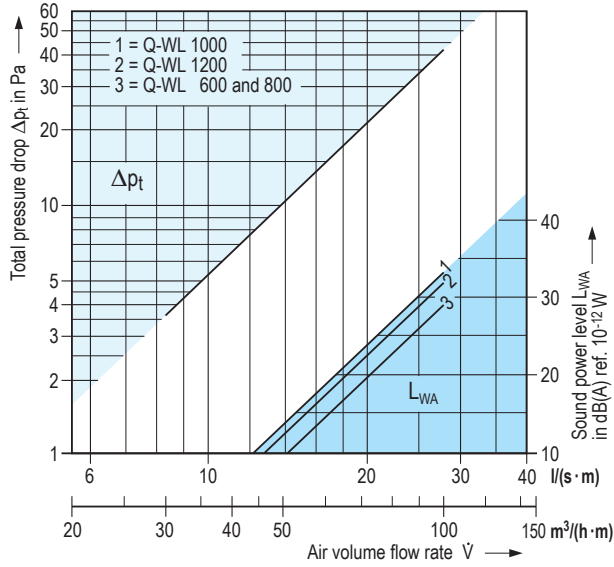

Type	L or DN mm	\dot{V}		Sound power level L_{WA} in dB ref. $10^{-12} W$								
		l/s	m^3/h	L_{WA} dB(A)	Octave band centre frequency in Hz							
					125	250	500	1 K	2 K	4 K	8 K	
Q-WL	600	16.5	60	29	27	24	27	26	18	13	9	
		14	50	22	22	17	20	18	11	6	4	
	800	22	80	29	29	24	28	25	17	13	10	
		18	65	22	23	17	20	18	12	6	5	
	1000	28	100	33	31	27	32	28	21	17	13	
		22	80	26	26	21	25	22	15	10	6	
	1200	33	120	32	32	27	31	28	20	16	13	
		26	95	25	26	20	23	21	13	9	6	
	Q-WR	80	16.5	60	29	31	25	27	25	15	7	—
			11	40	17	22	15	15	11	8	—	—
		100	28	100	32	32	28	29	29	22	16	11
			22	80	25	27	21	23	21	13	10	6
125		16.5	60	18	23	16	17	13	9	6	—	
		36	130	34	34	30	31	31	24	18	12	
30.5		110	29	31	26	27	25	16	8	—	—	
		25	90	23	25	19	21	19	11	9	5	
Q-WK		600	16.5	60	28	26	23	26	25	17	12	9
			14	50	21	21	16	19	17	9	6	4
		800	22	80	29	27	24	28	26	17	12	9
			18	65	22	23	17	20	17	11	7	5
	1000	28	100	32	32	27	31	28	20	16	13	
		22	80	26	26	20	23	21	13	9	6	
	1200	33	120	31	29	26	29	28	20	15	11	
		26	95	24	24	19	22	20	13	8	6	

Circular wall displacement outlet

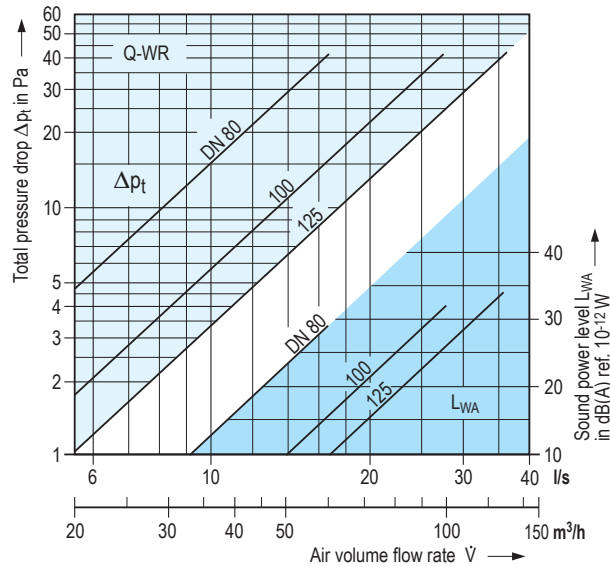

Combined wall displacement outlet

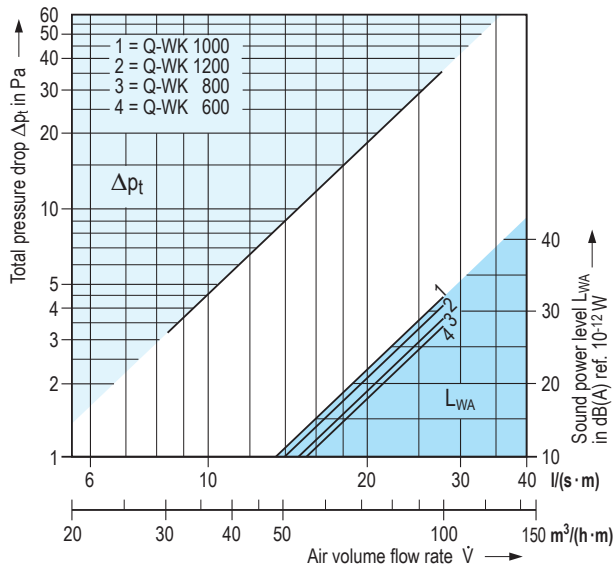

Features

- Low-turbulence air flow according to the principle of displacement ventilation
- For wall mounting at ceiling height (primarily in corridor walls)
- Three types: linear, circular, or combined with return air extraction
- Each type available in 3 or 4 sizes
- Volume flow rate up to 35 l/s or 28 l/(s · m) [125 m³/h or 100 m³/(h · m)]
- Minimum supply air temperature 16°C
- Temperature difference between supply and indoor air -1 to -6 K, between supply and return air up to -8 K
- Easy to combine with a chilled ceiling (with return air temperature \approx indoor air temperature)
- Draught-free indoor air flow with very low air velocities in the occupied zone
- Temperature differences in the occupied zone \leq 1 K
- Low sound power level (\leq 34 dB(A) ref. $10^{-12} W$)
- Penetration depth up to 6 m
- Mounting height: 2 to 4 m
- Minimum outlet-to-ceiling distance: 120 mm
- Material: sheet metal painted to RAL colour of choice

Type code

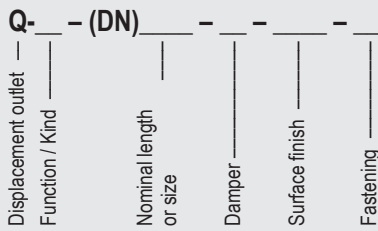

Function / Kind

WL = linear wall displacement outlet
 WR = circular wall displacement outlet
 WK = combined wall displacement outlet

Nominal length ¹⁾

600 = nominal length 600
 800 = nominal length 800
 1000 = nominal length 1000
 1200 = nominal length 1200

Size ²⁾

80 = DN 80
 100 = DN 100
 125 = DN 125

Damper ¹⁾

O = no volume flow damper
 R = with volume flow damper adjustable from room

Surface finish

9010 = face painted to RAL 9010, semi-matt

Fastening ²⁾

K = with claw fasteners
 L = with lip seal

Tender text

..... units

Wall displacement outlet for low-turbulence air flow according to the principle of displacement ventilation, for mounting in room walls at ceiling height, with finely perforated faceplate for air discharge.

Type

- **Linear wall displacement outlet** with rectangular housing, circular connection spigot, jet straightener, and perforated faceplate; option: volume flow damper adjustable from room.
- **Circular wall displacement outlet** with circular housing with exit flange, connection spigot, intake throttle, and perforated faceplate; fastening via claw fasteners or lip seal.
- **Combined wall displacement outlet** with rectangular housing divided into supply and return air segments with thermal partition, with connection spigots for supply air and return air, and perforated faceplate; option: volume flow damper adjustable from room.

Material:

Wall displacement outlet made of galvanized sheet metal. Faceplate and exit flange ²⁾ painted to RAL

Make: KRANTZ KOMPONENTEN

Type: Q-__ - (DN)___ - __ - ___ - __

¹⁾ For linear or combined wall displacement outlet

²⁾ For circular wall displacement outlet

Subject to technical alterations.