

**Please note,**  
type code is new,  
see on last page.

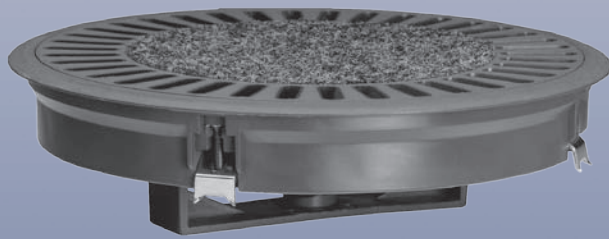

## NTK floor twist outlet DB-N-DN 215

### Preliminary remarks

NTK stands for “Neues Technisches Konzept” – new technical concept – and is the name for a system for adaptable office design that has been successfully used for several years in office air-conditioning. The NTK system also comprises a cavity floor for underfloor installation of electrical and telecommunications cabling and air supply. For the supply air distributed from the cavity floor into the room KRANTZ KOMPONENTEN provides a floor outlet called NTK floor twist outlet in the following.

### Construction design and function

The main components of the NTK floor twist outlet are the floor insert **1** with shaped protective ring for carpeting **2**, the inserted twist outlet **3** and the perforated throttle disk **5**.

The air outlet **3** has a number of radially arranged slots at its periphery. These generate a slim, stable air jet

which twists upwards with intensive induction of the room air and optimum length of air jet penetration into the room. Fig. 1 shows an example of the air jet pattern.

The NTK floor twist outlet is available in size DN 215, volume flow rate range 8.5 – 16.5 l/s (30 – 60 m<sup>3</sup>/h).

The volume flow rate is adjusted using the perforated throttle disk **5** which can be rotated manually.

The whole air outlet unit is installed in the floor opening **9** and screwed down with 4 claw fasteners **12**. The floor opening will be of the same type and size of that used for usual electrical and telecommunications cabling.

The carpet protection ring holds the air outlet. There is no need for stepped bores in the floor. Where necessary additional bores can be made with standard drilling tools.

The NTK floor twist outlet is available in polycarbonate. It has a recess **4** in the middle which is covered either with a polycarbonate lid **10** or with carpet **11** for a more attractive appearance.

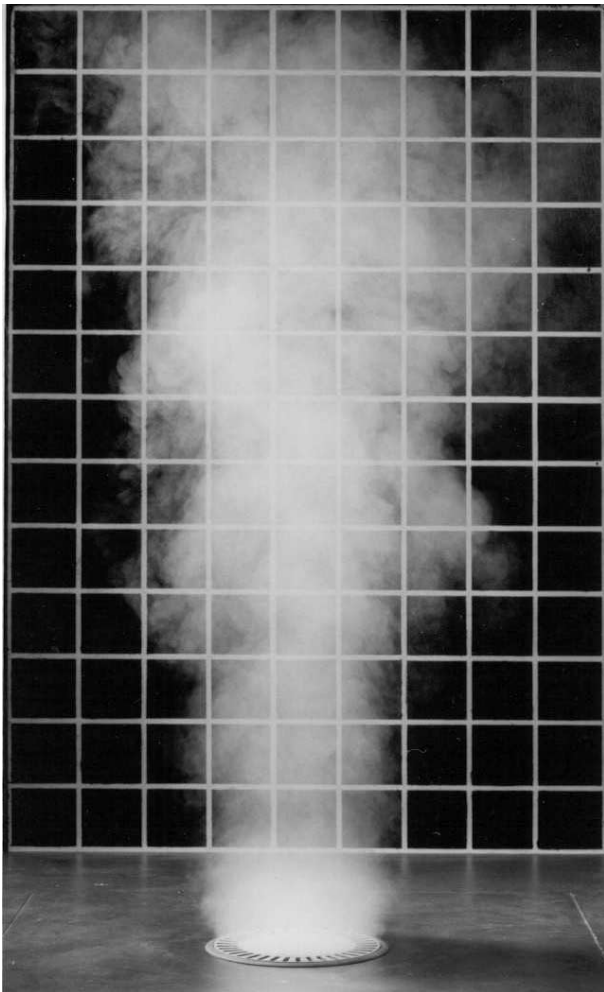

Figure 1: Example of jet pattern,  
volume flow rate: 11 l/s (40 m<sup>3</sup>/h)  
Temperature difference supply air–indoor air: – 4 K  
Grid: 10 cm x 10 cm

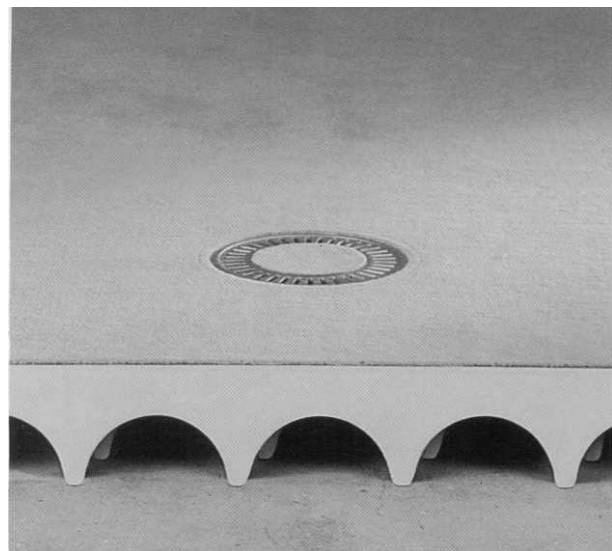
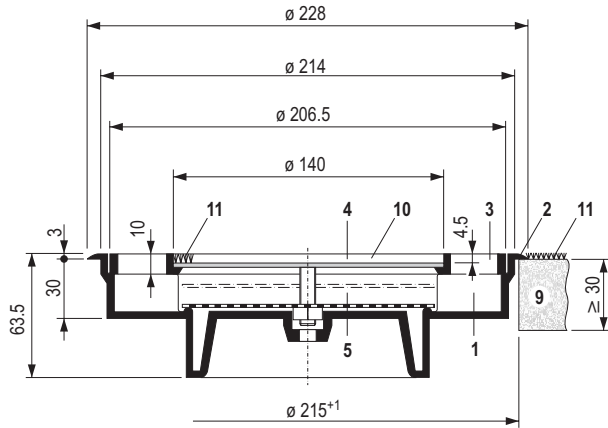

Figure 2: NTK floor twist outlet installed in cavity floor

# NTK floor twist outlet

## Dimensions and design specifications



with perforated throttle disk 5  
Type DB – N – DN 215 – D

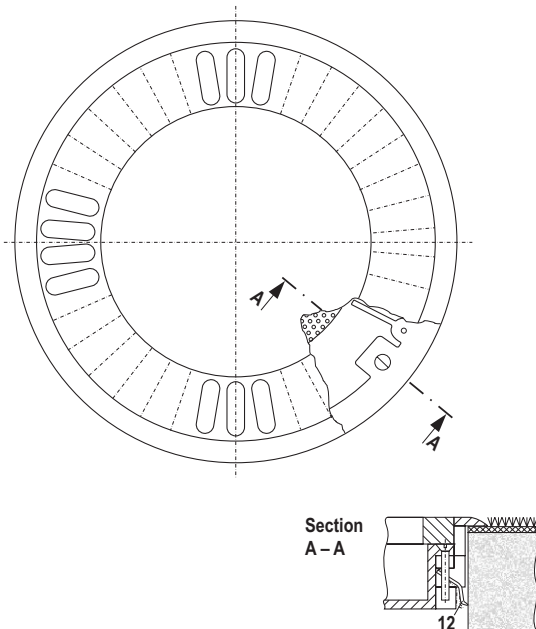

Figure 3: Dimensions of NTK floor twist outlet

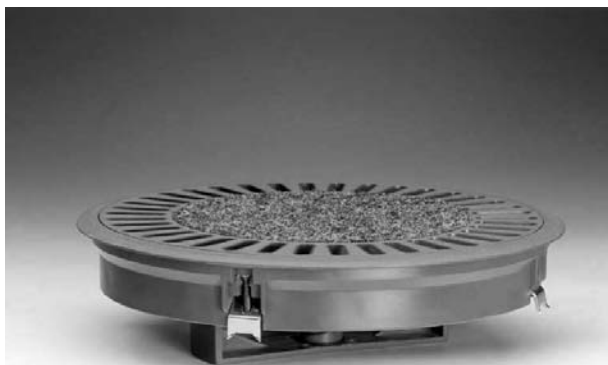

Figure 4: NTK floor twist outlet with carpet insert in the central recess

- Key:**
- 1 Floor insert
  - 2 Carpet protection ring
  - 3 Air outlet
  - 4 Central recess
  - 5 Perforated throttle disk
  - 9 Floor
  - 10 Lid made of polycarbonate (option)
  - 11 Carpet (option)
  - 12 Claw fastener



Figure 5: NTK floor twist outlet in an office building

### Design specifications:

NTK floor twist outlet	Unit	Size
Nominal diameter:	mm	DN 215
Air outlet volume flow rate:	l/s	8.5 - 16.5
	m <sup>3</sup> /h	30 - 60
Max. temperature difference supply air – return air	K	± 10
Supply air temperature:	°C	18 - 30
Minimum air outlet centre spacing:	m	approx. 0.6
Min. spacing to seats:	m	approx. 0.8
Installation diameter:	mm	214
Requisite diameter of floor opening:	mm	215
Max. load-bearing capacity <sup>1)</sup>	kg	200

1) For vertical single load on a central indent of 50 mm diameter

# NTK floor twist outlet

## Air discharge velocities above the air outlet

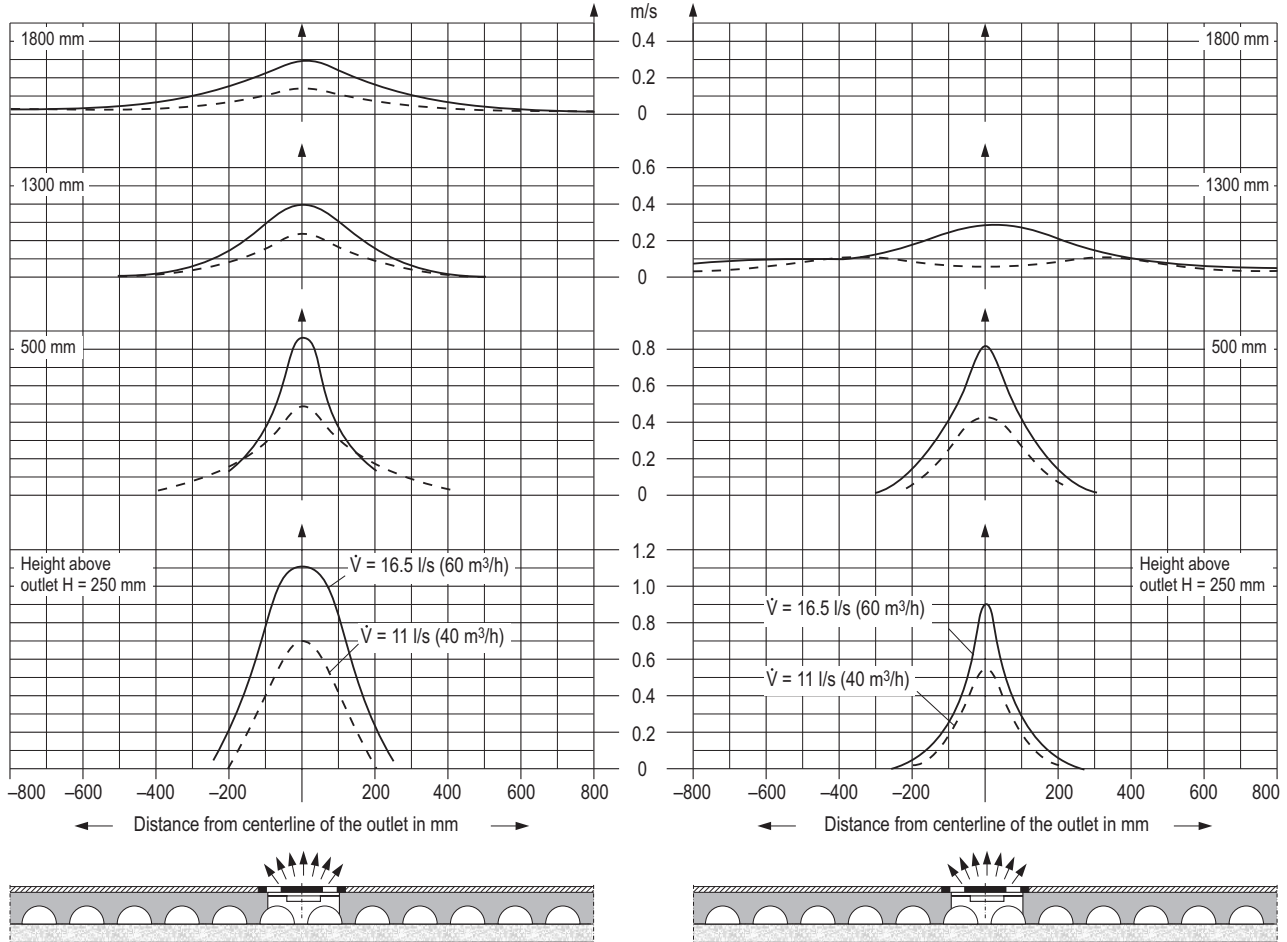

Figure 6: Air discharge velocities at various heights above the NTK floor twist outlet at a temperature difference between supply air and indoor air, at a height of 1.2 m, of left:  $\Delta\vartheta^* = 0\text{ K}$ , right:  $\Delta\vartheta^* = -4\text{ K}$

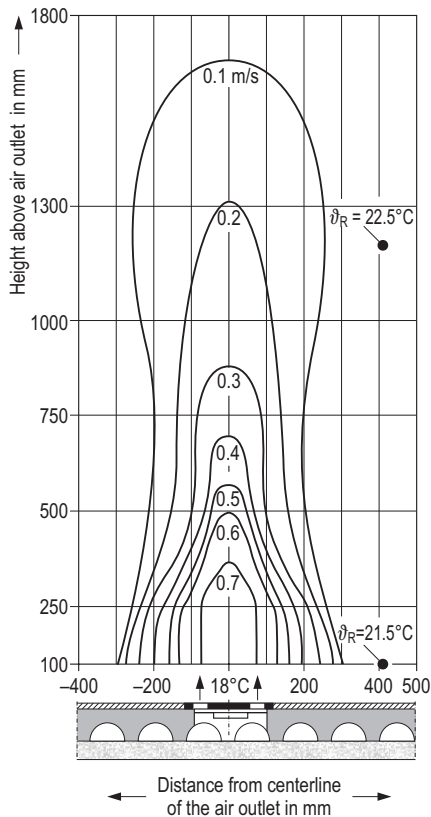

Figure 7: Maximum centerline air velocities,  $\dot{V}_A = 14\text{ l/s}$  ( $50\text{ m}^3/\text{h}$ ),

**Remarks on Figure 6:**

The chart for  $\dot{V}_A = 16.5\text{ l/s}$  ( $60\text{ m}^3/\text{h}$ ) and  $\Delta\vartheta^* = 0\text{ K}$  shows that at a height of 500 mm above the air outlet the jet velocity drops to about 0.9 m/s. The jet velocity continues to decrease rapidly as the height increases. From  $H = 1300\text{ mm}$  upwards the influence of the temperature difference is more noticeable. The colder air jet decelerates more quickly than the warmer jet. The following comparison shows for  $H = 1300\text{ mm}$ :

$$\Delta\vartheta^* = 0\text{ K} \rightarrow u_{\max} = 0.40\text{ m/s}$$

$$\Delta\vartheta^* = -4\text{ K} \rightarrow u_{\max} = 0.28\text{ m/s}$$

At a distance of about 500 mm from the jet axis, the supply air jet has no effect on comfort. The air velocities measured are below 0.1 m/s.

# NTK floor twist outlet

## Jet temperature, sound power level and pressure loss

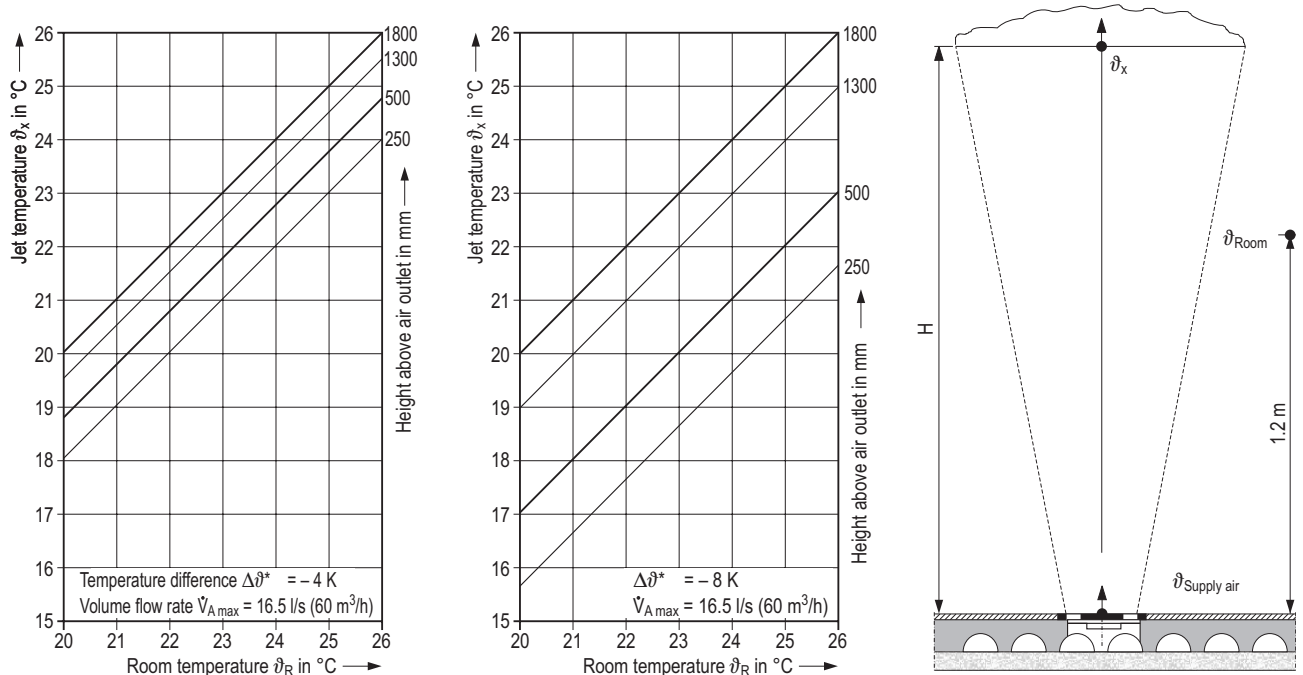
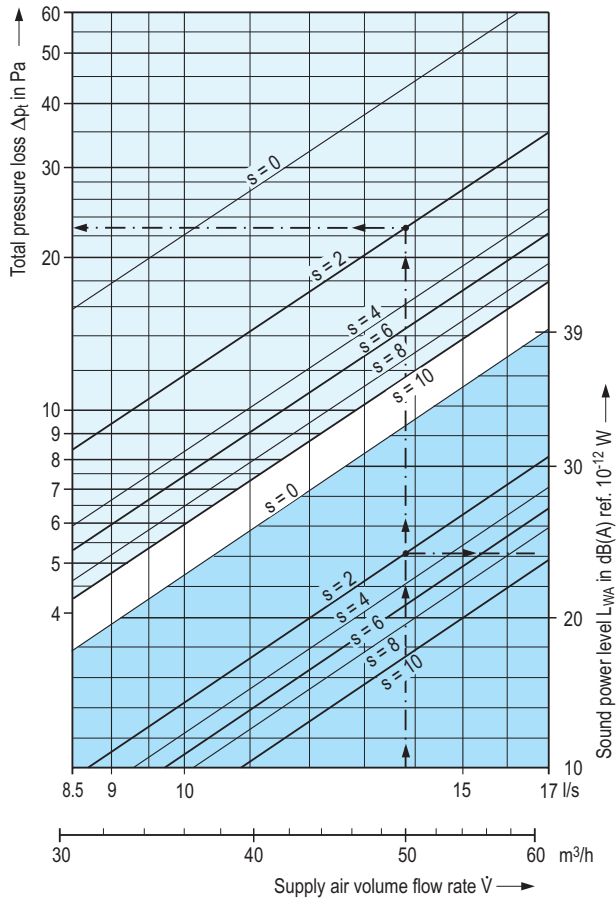

Figure 8: Jet temperature at different heights above NTK floor twist outlet



**Remarks**

$\Delta\vartheta^*$  = temperature difference between supply air ( $\vartheta_{Supply\ air}$ ) and occupied zone ( $\vartheta_{Room\ air}$  at a height of 1.2 m).  
 $\Delta\vartheta_x$  = temperature difference between jet ( $\vartheta_x$ ) and occupied zone ( $\vartheta_{Room}$  at a height of 1.2 m).  
 $\Delta\vartheta_x$  reduces rapidly in response to height. The percentage decrease in temperature difference is shown in the table.

Height H above air outlet	Size DN 215
250 mm	45 %
500 mm	65 %
1300 mm	85 %

At a height of 1800 mm above the air outlet jet temperature and room temperature are already fully equalized. This applies to the maximum air outlet volume flow rate. At lower air outlet volume flow rates the temperature equalizes even more rapidly.

**Key**

s = Opening of perforated throttle disk in mm

DS 1277 E Bl. 5 04.2005

Figure 9: Sound power level and pressure loss

Nominal size	Insertion loss in dB							Mean value	
	Octave band centre frequency in Hz								
DN	63	125	250	500	1000	2000	4000	8000	
215	10	10	7	7	6	7	12	17	10

### Features

- Slim vertical jet
- Stable air jet penetration depth
- Intensive mixing of supply air and indoor air
- Slight lateral interference
- Low temperature stratification in room
- Low sound power level
- Minimum supply air temperature 18°C
- Maximum temperature difference between supply air and return air ± 10 K
- With perforated throttle disk for volume flow rate adjustment during system balancing
- Fits same floor openings as for electrical and telecommunications cabling
- Floor fastening with 4 claw fasteners
- Material: polycarbonate, body-tinted to RAL 7037 (dusty grey)
- Can be walked and driven over, also with wheelchair

### Tender text

....units

NTK floor twist outlet for installation in cavity floor, round, for generating twisted, stable, vertical air jets, consisting of:

floor insert with shaped carpet protection ring and 4 claw fasteners,

air outlet element with radial air slots and central recess

for carpet insert of 4.5 mm thickness.

with lid.

perforated throttle disk for stepless adjustment of volume flow rate by hand (can be operated during system balancing).

### Technical data:

Volume flow rate: ..... l/s (m<sup>3</sup>/h)

Perm. sound power level: ..... dB(A) ref. 10<sup>-12</sup> W

Diameter:  214 mm, to fit floor opening Ø 215 mm

Max. load-bearing capacity <sup>1)</sup>: 200 kg

Material: polycarbonate, outer surfaces matted to be made scratch-resistant

Colour: body-tinted similar to RAL 7037

Make: KRANTZ KOMPONENTEN

Type: DB - N - DN 215 - D

### Type code

DB - N - DN 215 - D

Floor twist outlet  
Function / Kind  
Size  
Model

Please note,  
type code is new,  
see last page.

This outlet is also available  
as a floor displacement  
outlet

Function / Kind: N = NTK

Size: DN 215

Model:

D = perforated throttle disk

<sup>1)</sup> For vertical single load on a central indent of 50 mm diameter

Subject to technical alterations!

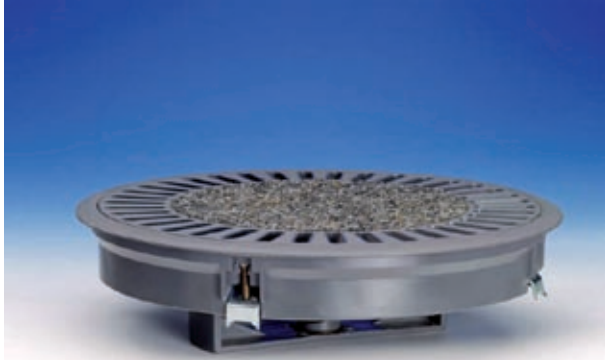

NTK floor twist outlet

## Type code

DB – N – DN 215 – D

Floor twist outlet  
Function / Kind:  
Size  
Model

**Function / Kind:** N = NTK

**Size:** DN 215

**Model:**

D = perforated throttle disk

Note:

Size DN 215 made of polycarbonate is also available as a floor displacement outlet

Subject to technical alteration.