

Please note,  
type code is new,  
see last page.

# Technical Selection

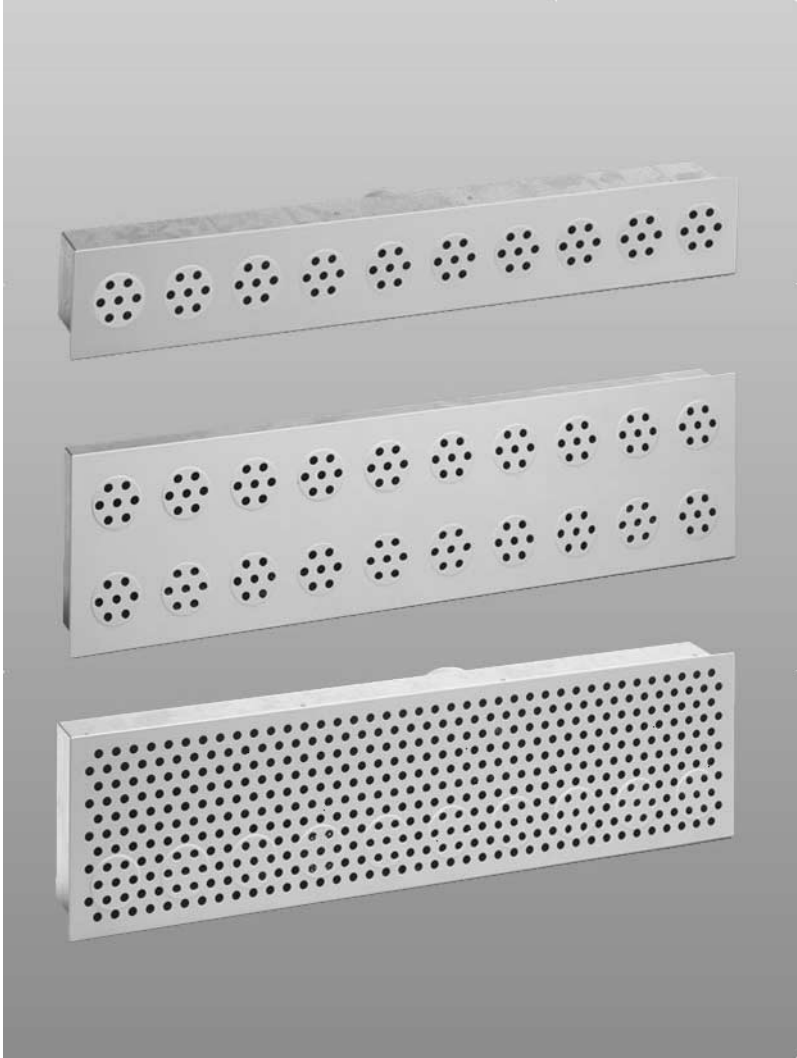

Multiplex outlet FA-V....

### Preliminary remarks

Traditionally, supply air outlets are installed in walls, close to the ceiling. Air grilles or slot outlets for linear air discharge give rise to tangential indoor air patterns that are likely to cause too high indoor air velocities.

Better indoor air flow conditions, however, can be achieved with air outlets capable of generating high-turbulence, diffuse mixing air flow while spreading the air jets. This preferable flow pattern is feasible with the multiplex outlet from KRANTZ KOMPONENTEN. The multiplex outlet is a sidewall air outlet whose frontal plate generates a large number of thin air jets through built-in jet bundle elements. The discharge direction of these elements being adjustable, the supply air jets can be spread out as required.

The multiplex outlet can also be used for return air intake. Further, it is available in a design combining a lower supply air segment and an upper return air segment.

### Construction design and function

The main components of the multiplex outlet are the rectangular housing **1** and the frontal plate **2** with several round jet bundle elements **3**. The frontal plate can be perforated or non-perforated and the jet bundle elements can be arranged in single or double rows.

The channels of the jet bundle elements have different discharge angles  $\alpha$  or  $\beta$ . By rotating the individual elements, the direction of the jet channels – and thus the discharge direction – can be adjusted to an upward or downward incline as well as to the right or left, which enables to spread out the supply air jets as required.

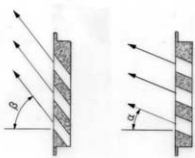

*Jet bundle elements with different discharge angles*

### Multiplex outlet for supply air: type FA-VT or FA-VTL

The frontal plate has either no perforations (type FA-VT) or, for reasons of appearance, the same perforations as the jet bundle elements (type FA-VTL). In both cases the air is discharged through the jet bundle elements only. This generates a stable, high-induction turbulent mixing air flow with many single jets. The jet bundle elements can be rotated to adjust the jet spread. Supply air and indoor air mix quickly and the jet velocity decays very fast. The supply air flow to the occupied zone is

draught-free even at high temperature differences between supply air and indoor air. No tangential air patterns form.

### Multiplex outlet for return air: type FA-VA or FA-VAL

The multiplex outlet can also be used for return air intake. For this purpose, the frontal plate can be supplied either with or without perforations.

### Combined multiplex outlet for supply and return air: type FA-VK or FA-VKL

The housing is divided into a lower supply air segment and an upper return air segment. Here too, the frontal plate can be non-perforated (type FA-VK) or perforated (type FA-VKL). The return air segment of the perforated type has no jet bundle elements for air intake. Instead, the perforations are unobstructed so that the return air flows into the air outlet through the free perforations.

### Generally:

The frontal plate of the multiplex outlet is fastened by means of a push-in connection and can be removed from the room side. It is easy to clean, whether it has perforations or not. At the rear of the housing is a circular connection spigot **4** for duct connection.

The combined multiplex outlet has two connection spigots, one for supply air and one for return air. These spigots are available with a volume flow damper **6** that will be operated from the room.

To make use of the advantageous flow pattern of the multiplex outlet, existing supply air grilles can be replaced with multiplex outlets (on request). In such case, the frontal plate of the multiplex outlet is simply inserted into the mounting frame of the existing supply air grille.

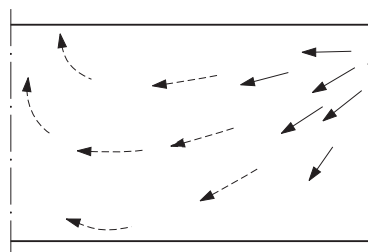
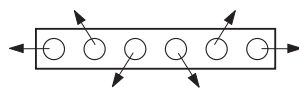

*Flow pattern at standard setting; the jet bundle elements (top sketch) can be rotated manually*



*Jet pattern made visible with smoke tracer*

Non-perforated frontal plate    Perforated frontal plate  
Supply air: Type FA-VT            Type FA-VTL  
Return air: Type FA-VA            Type FA-VAL

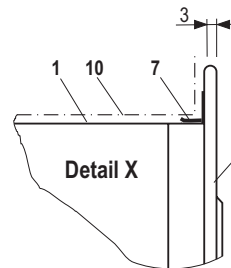
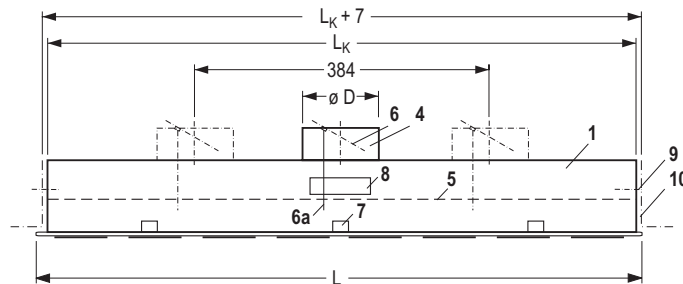
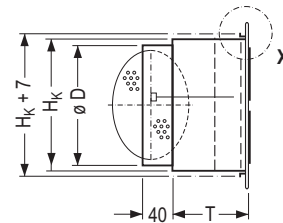
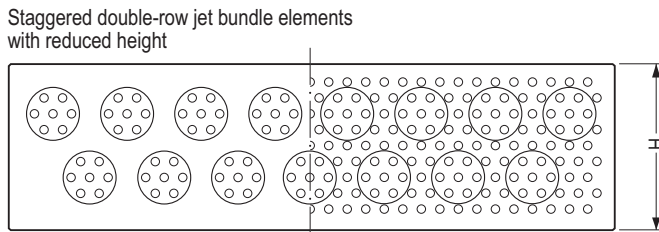
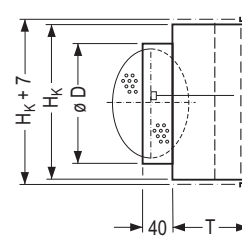
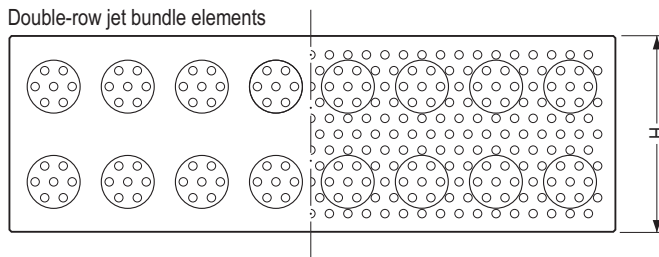
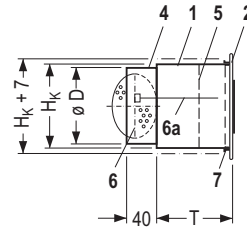
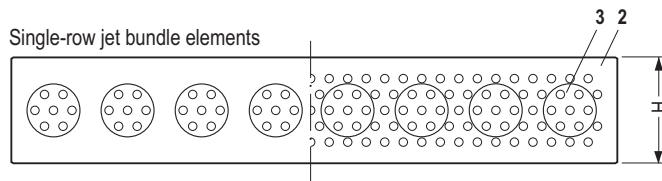

**Key for all pages**

- 1 Housing
- 2 Removable frontal plate
- 3 Jet bundle element
- 4 Connection spigot
- 5 Fixed damper
- 6 Volume flow damper
- 6a Adjustment from room
- 7 Push-in connection
- 8 Mounting detail
- 9 Wall fastener (by others)
- 10 Wall

Type	Nominal length $L_N$	Actual length $L$ mm	Length of housing $L_K$ mm	Number of jet bundle elements $n$ Units	Depth $T^{1)}$ mm	Types FA-VT / VTL (supply air) and FA-VA / VAL (return air)			
						Diameter $D$ mm	Dimensions and weight		
						$D$	$H$	$H_K$	$G$ approx. kg
Single-row	600	606	580	6	100	99	140	110	3.2
	800	798	772	8		99 <sup>2)</sup>			4.1
	1000	990	964	10		99 <sup>3)</sup>			4.8
Double-row	600	606	580	12	100	124	260	230	4.7
	800	798	772	16		149			5.4
	1000	990	964	20		159			6.1
Staggered double-row	600	606	580	11	100	124	220	190	4.5
	800	798	772	15		149			5.2
	1000	990	964	19		159			5.9

1) For connection box with acoustic lining:  $T+20$  mm  
2) Supply air outlet with 2 spigots  $\varnothing 79$  if required

3) Supply air outlet with 2 spigots  $\varnothing 99$  if required

Non-perforated frontal plate Type FA-VK    Perforated frontal plate Type FA-VKL

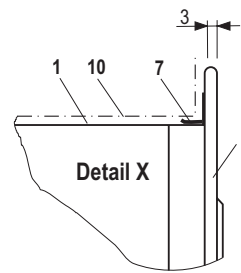
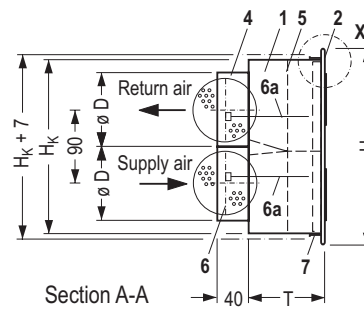
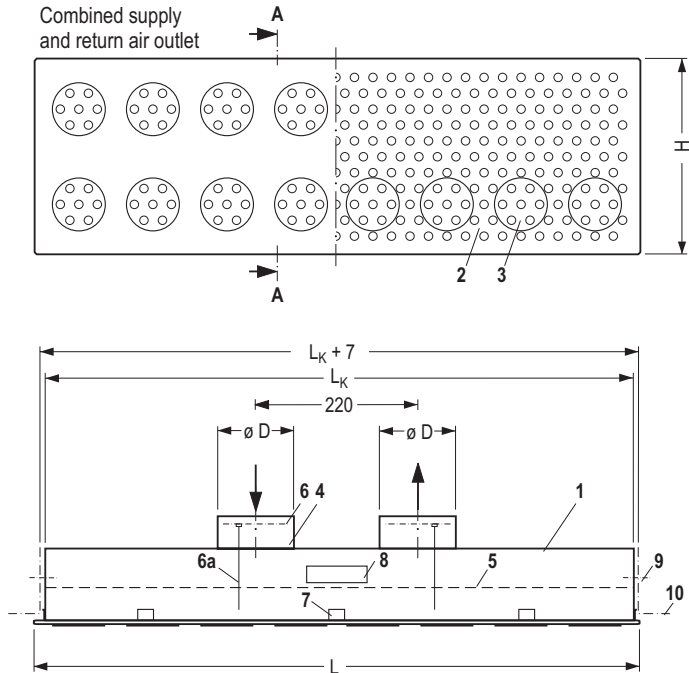

Type	Nominal length $L_N$	Actual length $L$ mm	Length of housing $L_K$ mm	Number of jet bundle elements		Depth $T$ <sup>1)</sup> mm	Types FA-VK and FA-VKL			
				VK	VKL		Dimensions and weights			
				$n$	Units	Diameter $D$ mm	$H$ mm	$H_K$ mm	$G$ approx. kg	
Single-row	600	606	580	12	6	100	99	260	230	4.8
	800	798	772	16	8		124			5.5
	1 000	990	964	20	10		124			6.2

1) For connection box with acoustic lining:  $T+20$  mm

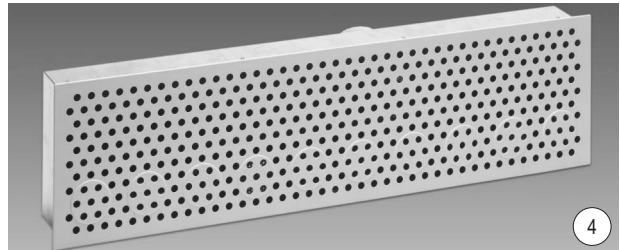
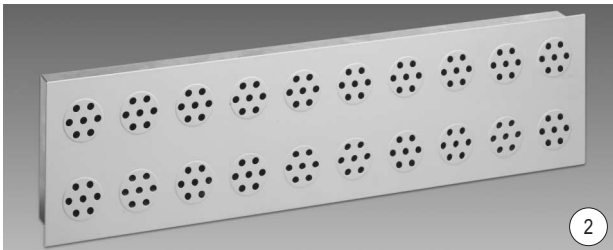
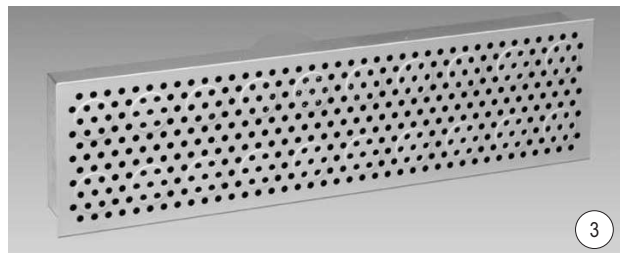

Multiplex outlets for supply air or return air, with non-perforated frontal plates; jet bundle elements arranged in single row ① or double row ②.

Multiplex outlet for supply air or return air with perforated frontal plate ③, jet bundle elements arranged in double row, and combined multiplex outlet for supply and return air ④, perforated frontal plate with jet bundle elements in lower supply air segment. The jet bundle elements can be rotated manually to alter the discharge direction.

### Layout specifications

At standard setting of the jet bundle elements (jets spread out), a jet penetration depth of up to 2.5 m and a supply air coverage of up to approx. 6 m are obtained. It is advantageous to arrange the air outlets with sufficient spacing to one another so as to make full use of the jet spreading. The maximum temperature differences between supply air and indoor air can amount to -12 K when cooling and +15 K when heating.

### Comfort criteria

The layout of the multiplex outlet is based on compliance with the required maximum permissible indoor air velocities. The maximum specific air volume flow rate  $\dot{V}_{Sp\ max}$ , the maximum air volume flow rate per air outlet  $\dot{V}_A\ max$  and the minimum air outlet spacing  $t_{min}$  are dependent on the discharge height and the maximum permissible indoor air velocity and can be determined using the graph below and the following equations.

The layout criterion is based on  $\Delta\vartheta_{max} = -10$  to  $-12$  K. If the maximum temperature difference is lower,  $\dot{V}_{Sp\ max}$  can be increased by the following percentage:

- $\Delta\vartheta_{max} = -8$  K  $\Rightarrow \dot{V}_{Sp\ max}$  15% higher
- $\Delta\vartheta_{max} = -6$  K  $\Rightarrow \dot{V}_{Sp\ max}$  35% higher
- $\Delta\vartheta_{max} = -4$  K  $\Rightarrow \dot{V}_{Sp\ max}$  70% higher

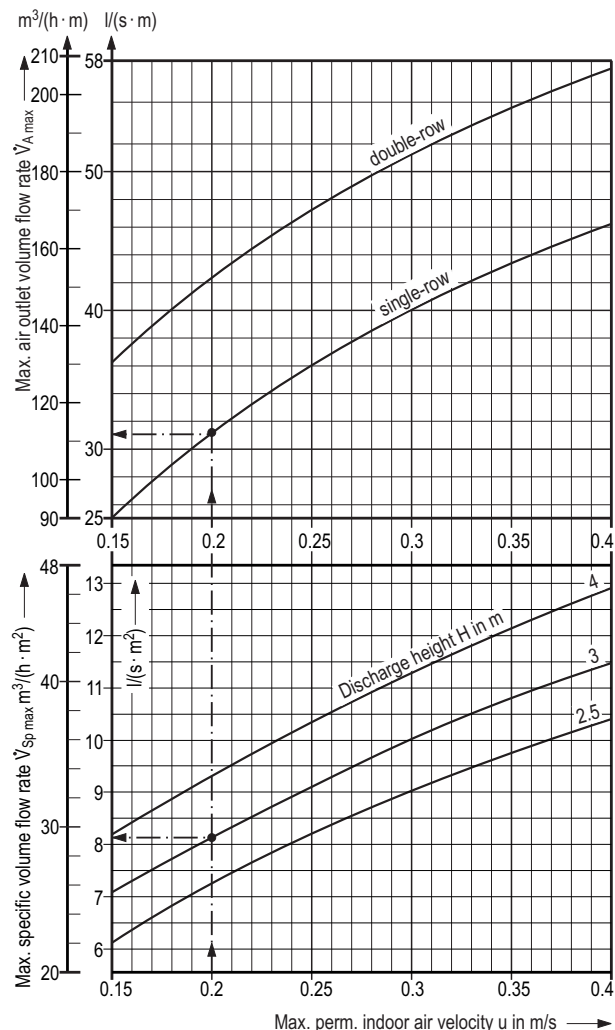

### Coverage width and minimum spacing

The coverage width  $E$  and the minimum air outlet spacing  $t_{min}$  can be determined on the basis of the maximum specific volume flow rate  $\dot{V}_{Sp\ max}$  and the coverage length  $L_E$ :

$$E = \frac{\dot{V}_A}{\dot{V}_{Sp\ max} \cdot L_E} \quad t_{min} = E - L_A$$

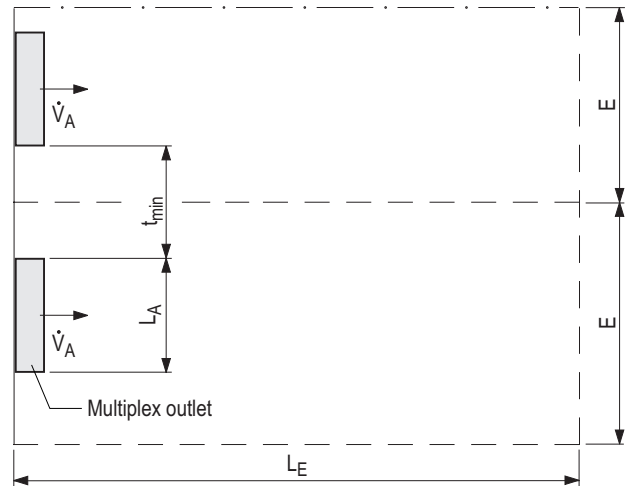

Coverage width  $E$ , coverage length  $L_E$  and minimum spacing  $t_{min}$

#### Layout example for supply air outlets installed in an office

- 1 Room width  $B_R$  = 8 m
- 2 Room depth  $B_T$  = 5 m
- 3 Total supply air volume flow rate  $\dot{V}_G$  = 185.5 l/s
- 4 Discharge height  $H$  = 3 m
- 5 Indoor air temperature  $\vartheta_R$  = 26°C (at max. cooling load)
- 6 Max. permissible indoor air velocity  $u$  = 0.2 m/s
- 7 Permissible sound power level  $L_{WA}$  = 35 dB(A) ref. 10<sup>-12</sup> W
- 8 Actual specific volume flow rate  $\dot{V}_{Spez}$  = 4.6 l/(s · m) [3 : (1 · 2)]
- 9 **Double-row** multiplex outlet, type FA-VT or FA-VTL,  $L_N = 1.0$  m

#### From graph

- 10  $\dot{V}_{Sp\ max} = 8.1$  l/(s · m<sup>2</sup>)
- 11  $\dot{V}_A\ max = 33.1$  l/(s · m)
- 12  $L_N\ total = 5.9$  m [3 : 11]
- 13  $n \approx 6$  units [12 : 9]
- 14  $\dot{V}_A\ gew \approx 30.5$  l/s [3 : 13]
- 15  $t = \frac{B_R - (6 \cdot 1.0)}{6} = 0.33$  m
- 16  $L_{WA} \approx 33$  dB(A) ref. 10<sup>-12</sup> W [Graph Page 6]
- 17  $\Delta p_t = 36$  Pa [Graph Page 6]

#### Checking specific volume flow rates

- 18  $\dot{V}_{Spez} < \dot{V}_{Sp\ max} = 4.6 < 8.1$  l/(s · m<sup>2</sup>) [8 < 10]
- 19  $\dot{V}_A\ gew < \dot{V}_A\ max = 30.5 < 33.1$  l/(s · m) [14 < 11]

#### Key to pages 5 and 6

- $\dot{V}_A$  = Supply air volume flow rate per air outlet
- $\dot{V}_A\ max$  = Max. volume flow rate per m of air outlet depending on discharge height  $H$  and permissible indoor air velocity  $u$
- $\dot{V}_A\ gew$  = Selected volume flow rate, taking account of permissible sound pressure level
- $\dot{V}_{Spez}$  = Actual specific volume flow rate per m<sup>2</sup> of floor area
- $\dot{V}_{Sp\ max}$  = Max. specific volume flow rate per m<sup>2</sup> of floor area
- $u$  = Max. permissible indoor air velocity, in m/s
- $E$  = Coverage width
- $L_E$  = Coverage length
- $t_{min}$  = Minimum air outlet spacing
- $L_A$  = Air outlet length

### Supply air, FA-VT and FA-VTL<sup>1)</sup>

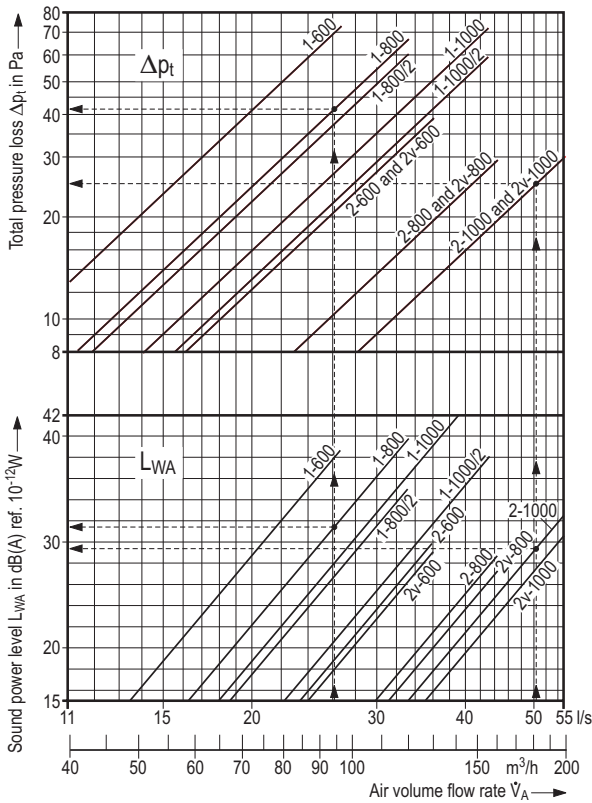

### Return air, FA-VA and FA-VAL<sup>1)</sup>

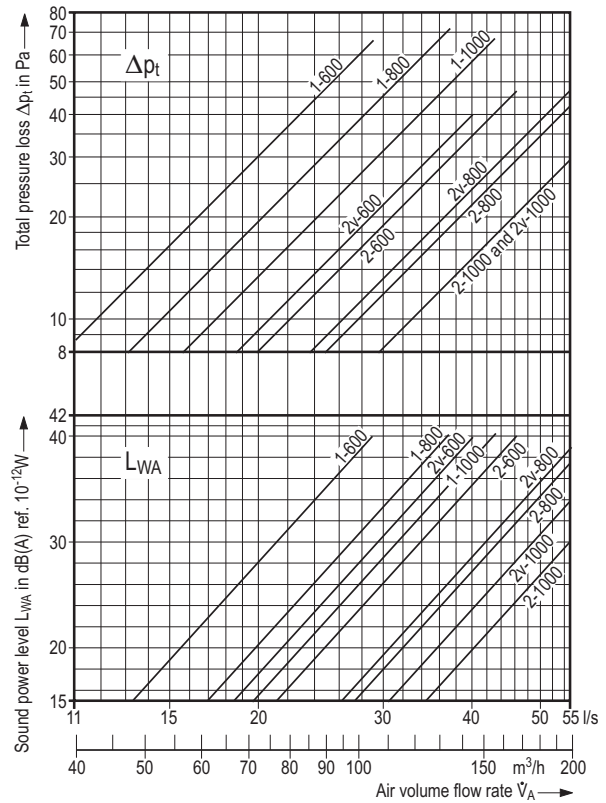

### Supply and return air combined, FA-VK and FA-VKL<sup>1+2)</sup>

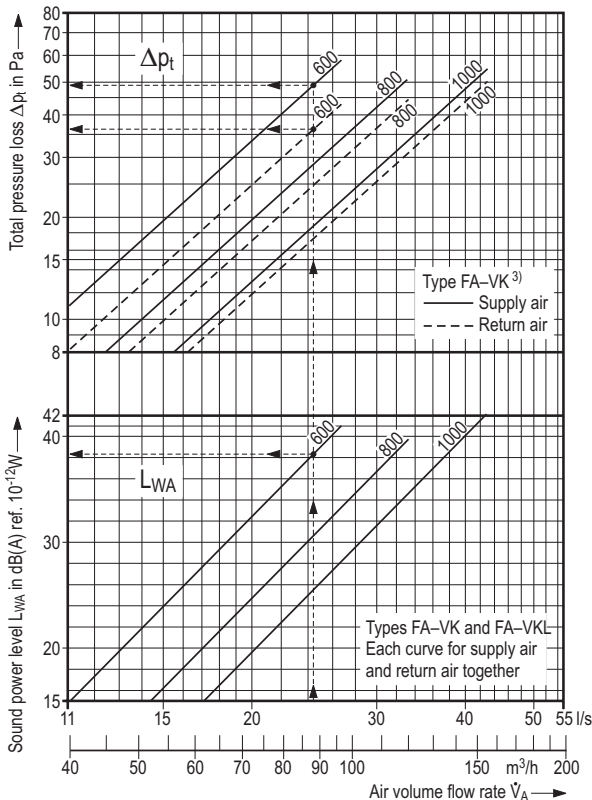

#### Types

Types	Nominal length
1 Single-row	
2 Double-row	600
2v Staggered double-row	800
/2 with two connection spigots	1000

Example: 2-800

Double-row jet bundle elements, nominal length 800

### Features

- Sidewall air outlet for turbulent mixing air flow
- Spreading of supply air flow as desired by altering the discharge direction at built-in rotatable jet bundle elements
- Rapid reduction of jet velocity and temperature difference between supply air and indoor air due to single, thin air jets
- No tangential air patterns
- Maximum temperature difference between supply air and indoor air:  $-12\text{ K}$  when cooling and  $+15\text{ K}$  when heating (up to 3 m room height)
- Low sound power level
- Flush installation in upper wall area, discharge height 2.5 to 4 m
- Single-row and double-row design available
- Volume flow rate up to  $43\text{ l/(s} \cdot \text{m)}$  [ $155\text{ m}^3/(\text{h} \cdot \text{m)}$ ] for single-row design and up to  $51.5\text{ l/(s} \cdot \text{m)}$  [ $185\text{ m}^3/(\text{h} \cdot \text{m)}$ ] for double-row design
- Nominal lengths: 600, 800, 1 000
- Visible part of frontal plate painted to RAL 9010, pure white, jet bundle elements body-tinted (similar to RAL 9010, pure white); other colours on request
- Painted frontal plate easy to clean
- Can also be used for return air intake
- Also available as combined supply and return air outlet with common housing
- Well suited for replacing simple air grilles

1) Values for outlet housing with acoustic lining on request

2) The layout of the combined multiplex outlets is in line with the example of page 5. The return air flow rate equals the supply air flow rate.

3) For type FA-VKL the pressure loss values are lower by approx. 15% for supply air and by approx. 35% for return air.

# Multiplex outlet

Sound power level and pressure loss <sup>1)</sup>

Supply air outlets FA-VT and FA-VTL <sup>1)</sup>											
Type	Nominal length LN	Volume flow rate		Total pressure loss		Sound power level L <sub>w</sub> in dB ref. 10 <sup>-12</sup> W					
		V <sub>A</sub> l/s	V <sub>A</sub> m <sup>3</sup> /h	Δp <sub>t</sub> Pa	L <sub>WA</sub> dB(A)	Octave band centre frequency in Hz					
						125	250	500	1 K	2 K	4 K
Single-row	600	14	50	20	16	20	17	13	—	—	—
		18	65	34	25	21	30	24	13	—	—
		22	80	50	32	23	35	32	24	19	—
		26.5	95	72	38	24	40	38	31	28	17
	800	18	65	20	19	21	24	17	10	—	—
		24	85	34	28	25	32	27	19	—	—
		29	105	52	35	32	38	35	29	20	—
		33	120	67	40	31	41	40	35	29	17
	1000	22	80	20	22	28	26	21	12	—	—
		29	105	34	32	29	35	32	25	11	—
		36	130	52	39	31	39	39	34	24	—
		43	155	72	45	32	45	45	40	32	20
	800/2 <sup>5)</sup>	18	65	18	15	18	15	10	—	—	—
		24	85	31	23	18	27	22	12	—	—
		29	105	48	31	23	34	31	23	15	—
33		120	62	35	27	36	35	30	22	14	
1000/2 <sup>5)</sup>	22	80	16	15	19	14	14	—	—	—	
	29	105	27	24	24	26	25	12	—	—	
	36	130	42	31	25	32	31	22	15	—	
	43	155	60	37	27	37	38	30	24	12	
Double-row	600	22	80	15	13	21	11	—	—	—	—
		25	90	19	16	19	19	12	—	—	—
		28	100	24	20	21	25	17	10	—	—
		30.5	110	28	23	23	28	22	12	—	—
	800	28	100	12	12	17	10	10	—	—	—
		32	115	16	17	19	20	14	—	—	—
		36	130	20	20	20	24	19	10	—	—
		41.5	150	26	25	22	30	24	17	< 10	< 10
	1000	30.5	110	9	11	13	10	10	—	—	—
		37.5	135	14	18	18	23	16	—	—	—
		44.5	160	20	24	22	28	24	14	—	—
		51.5	185	26	29	27	33	30	22	—	—
Staggered double-row	600	22	80	15	14	17	11	12	—	—	—
		25	90	19	18	21	19	17	—	—	—
		28	100	24	21	22	25	21	—	—	—
		30.5	110	28	25	23	29	25	16	< 10	< 10
	800	28	100	12	13	17	13	10	—	—	—
		32	115	16	18	21	21	16	—	—	—
		36	130	20	22	23	26	22	—	—	—
		41.5	150	26	27	26	31	27	18	< 10	< 10
	1000	30.5	110	9	13	20	16	16	—	—	—
		37.5	135	14	19	23	24	17	—	—	—
		44.5	160	20	25	25	30	24	15	—	—
		51.5	185	26	30	29	34	29	23	11	—

Return air outlets FA-VA and FA-VAL <sup>1)</sup>											
Type	Nominal length LN	Volume flow rate		Total pressure loss		Sound power level L <sub>w</sub> in dB ref. 10 <sup>-12</sup> W					
		V <sub>A</sub> l/s	V <sub>A</sub> m <sup>3</sup> /h	Δp <sub>t</sub> Pa	L <sub>WA</sub> dB(A)	Octave band centre frequency in Hz					
						125	250	500	1 K	2 K	4 K
Single-row	600	14	50	14	17	18	17	—	—	—	—
		18	65	22	25	23	25	25	18	16	—
		22	80	38	32	26	32	30	26	25	—
		26.5	95	55	37	27	33	34	30	32	17
	800	18	65	16	17	20	15	17	—	—	—
		24	85	27	26	26	28	26	18	16	—
		29	105	43	33	28	33	32	27	25	—
		33	120	58	37	33	37	35	31	31	17
	1000	22	80	17	19	25	22	18	—	—	—
		29	105	29	28	30	30	28	20	16	—
		36	130	46	34	33	35	33	28	26	11
		43	155	66	40	37	39	39	34	32	19
Double-row	600	22	80	10	17	19	18	17	—	—	—
		25	90	13	20	20	21	21	10	—	—
		28	100	16	24	21	24	25	15	—	—
		30.5	110	20	27	22	26	28	20	15	—
	800	28	100	10	16	19	16	15	—	—	—
		32	115	14	20	20	21	21	—	—	—
		36	130	17	24	22	24	25	16	—	—
		41.5	150	24	28	24	28	28	22	15	< 10
	1000	30.5	110	9	12	16	12	—	—	—	—
		37.5	135	13	18	18	20	18	—	—	—
		44.5	160	19	23	21	24	24	15	—	—
		51.5	185	25	27	27	28	27	20	15	—
Staggered double-row	600	22	80	12	21	18	20	23	—	—	—
		25	90	15	24	19	22	26	15	—	—
		28	100	19	28	20	26	29	21	14	—
		30.5	110	23	31	25	27	32	25	18	—
	800	28	100	11	17	19	21	16	—	—	—
		32	115	15	22	21	24	22	14	—	—
		36	130	19	25	23	25	26	18	10	—
		41.5	150	26	30	25	30	30	24	17	< 10
	1000	30.5	110	9	15	17	16	15	—	—	—
		37.5	135	13	21	19	23	21	13	—	—
		44.5	160	19	27	24	27	27	18	11	—
		51.5	185	25	31	27	30	32	24	17	—

Combined supply and return air outlets FA-VK and FA-VKL <sup>1)</sup>												
Type	Nominal length LN	Volume flow rate <sup>2)</sup>		Total pressure loss <sup>3)</sup>		Sound power level L <sub>w</sub> in dB ref. 10 <sup>-12</sup> W <sup>4)</sup>						
		V <sub>A</sub> l/s	V <sub>A</sub> m <sup>3</sup> /h	Δp <sub>t</sub> Pa	Δp <sub>t</sub> Pa	L <sub>WA</sub> dB(A)	Octave band centre frequency in Hz					
							125	250	500	1 K	2 K	4 K
Single-row	600	11	40	11	8	15	19	17	13	—	—	—
		17	60	24	18	27	22	29	28	17	12	—
		22	80	43	30	35	28	35	35	29	26	10
		26.5	95	58	42	40	31	39	39	34	32	18
	800	17	60	14	12	20	21	23	19	12	—	—
		24	85	27	23	29	25	29	29	23	16	—
		29	105	40	35	36	28	34	36	30	27	10
		33	120	50	44	40	32	37	38	35	34	19
	1000	19	70	12	11	19	21	20	19	10	—	—
		28	100	24	22	29	25	30	29	23	17	—
		36	130	40	38	37	32	36	37	31	28	11
		43	155	54	50	42	34	40	41	37	35	20

Insertion loss in dB						
Type	Octave band centre frequency in Hz					
	125	250	500	1000	2000	4000
FA-VT / -VTL						
– Single-row	1	1	3	4	4	7
– Double-row	1	1	2	5	8	8
FA-VA / -VAL						
– Single-row	1	1	3	6	4	7
– Double-row	1	1	4	5	8	8
FA-VK						
– Supply air side	0	1	3	5	7	11
– Return air side	0	1	3	3	7	8
FA-VKL						
– Supply air side	0	1	2	2	5	6
– Return air side	0	1	1	1	2	4

- 1) Values for design with acoustic lining on request
- 2) For supply air and return air respectively
- 3) Applies for type FA-VK. For type FA-VKL the pressure loss values are lower by approx. 15% for supply air and by approx. 35% for return air
- 4) Applies for FA-VK and FA-VKL, for supply air and return air together
- 5) With 2 connection spigots

### Type code

FA - V - - - -

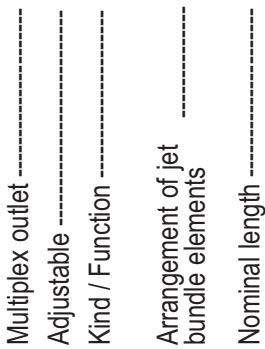

### Kind / Function

- T = For supply air, turbulent mixing air flow
- A = For return air
- L = Perforated frontal plate
- K = Combined supply and return air outlet, non-perforated frontal plate
- KL = Combined supply and return air outlet, perforated frontal plate

Please note, type code is new, see last page.

### Tender text

..... units - Multiplex outlet for flush installation in the upper area of a room wall, with rectangular housing, rear air connection via connection spigot<sup>1)</sup> fitted with V damper adjustable from the room; types available:

**Multiplex outlet for supply air** with frontal plate fitted with round jet bundle elements, each manually rotatable for supply air jet spread as desired by altering the discharge direction; rapid reduction of jet velocity and temperature difference between supply air and indoor air.

Frontal plate  non-perforated  perforated.

Arrangement of jet bundle elements

single-row  double-row  staggered double-row.

Supply air discharge through jet bundle elements.

**Multiplex outlet for return air**

with frontal plate fitted with round jet bundle elements, frontal plate  non-perforated  perforated.

Arrangement of jet bundle elements

single-row  double-row  staggered double-row.

Return air intake through jet bundle elements.

**Combined multiplex outlet for supply and return air** with common frontal plate,

non-perforated, with round jet bundle elements in lower supply air and upper return air segments; supply air discharge and return air intake through jet bundle elements.

perforated, with round jet bundle elements in lower supply air segment; supply air discharge through jet bundle elements, return air intake through free perforations in upper return air segment.

Jet bundle elements for supply air manually and individually rotatable for air jet spread as desired by altering the discharge direction; rapid reduction of jet velocity and temperature difference supply air-indoor air.

### Material:

- jet bundle elements: acrylonitrile-butadiene-styrene ABS body-tinted similar to RAL 9010, pure white,
- housing and frontal plate: galvanized sheet metal visible part of frontal plate painted to RAL 9010, pure white<sup>2)</sup>

### Dimensions of frontal plate:

- Nominal length L<sub>N</sub>: .....
- Height H: ..... mm

### Technical data

Volume flow rate: ..... l/s (m<sup>3</sup>/h)

Permissible sound power level: .....dB(A) ref. 10<sup>-12</sup>W

Pressure loss: ..... Pa

Make: KRANTZ KOMponenten

Type: FA - V - - - -

### Arrangement of bundle elements

1 = single-row

2 = double-row

2v = staggered double-row

### Nominal length

600, 800, 1000

Possible types as examples for nominal length 800

Figure	For supply air	For return air
1	FA-VT-1-800	FA-VA-1-800
2	FA-VTL-1-800	FA-VAL-1-800
3	FA-VT-2-800	FA-VA-2-800
4	FA-VTL-2-800	FA-VAL-2-800
5	FA-VT-2v-800	FA-VA-2v-800
6	FA-VTL-2v-800	FA-VAL-2v-800
<b>Combined supply and return air outlet</b>		
7	FA-VK-1-800	
8	FA-VKL-1-800	

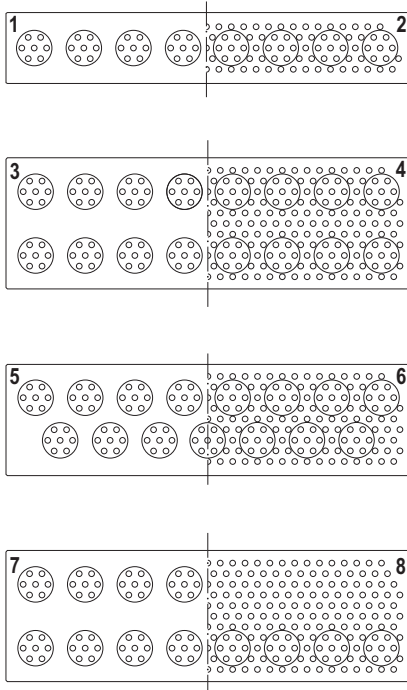

1) With lip seal on request  
2) Other colours on request



Multiplex outlet, single row

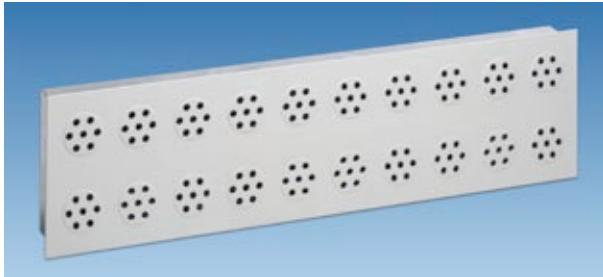

Multiplex outlet, double row

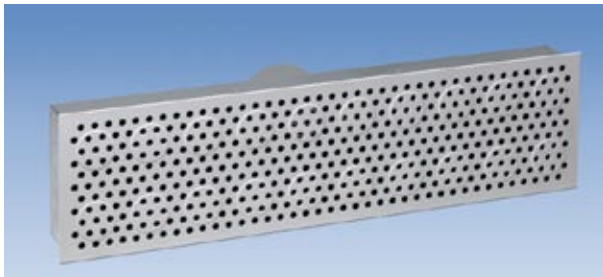

Multiplex outlet, double row with perforated frontal plate



Combined multiplex outlet with perforated frontal plate (single row)

## Type code

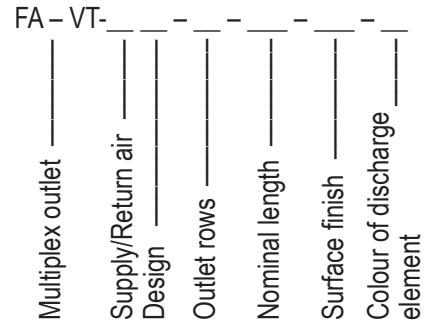

## Supply/Return air

- Z = Supply air
- A = Return air
- K = Combined

## Design

- O = non-perforated front plate
- L = perforated front plate

## Outlet rows <sup>1)</sup>

- 1 = 1 row
- 2 = 2 rows
- 2v = 2 rows, staggered

## Nominal length

- 600 = Nominal length 600
- 800 = Nominal length 800
- 1000 = Nominal length 1000

## Surface finish

- 9010 = Face painted to RAL9010, semi-matt

## Colour of discharge element

- S = black similar to RAL 9005
- W = white similar to RAL 9010

Subject to technical alteration.

<sup>1)</sup> each option for supply air or return air