

Please note,  
type code is new,  
see last page.

## Technical Selection

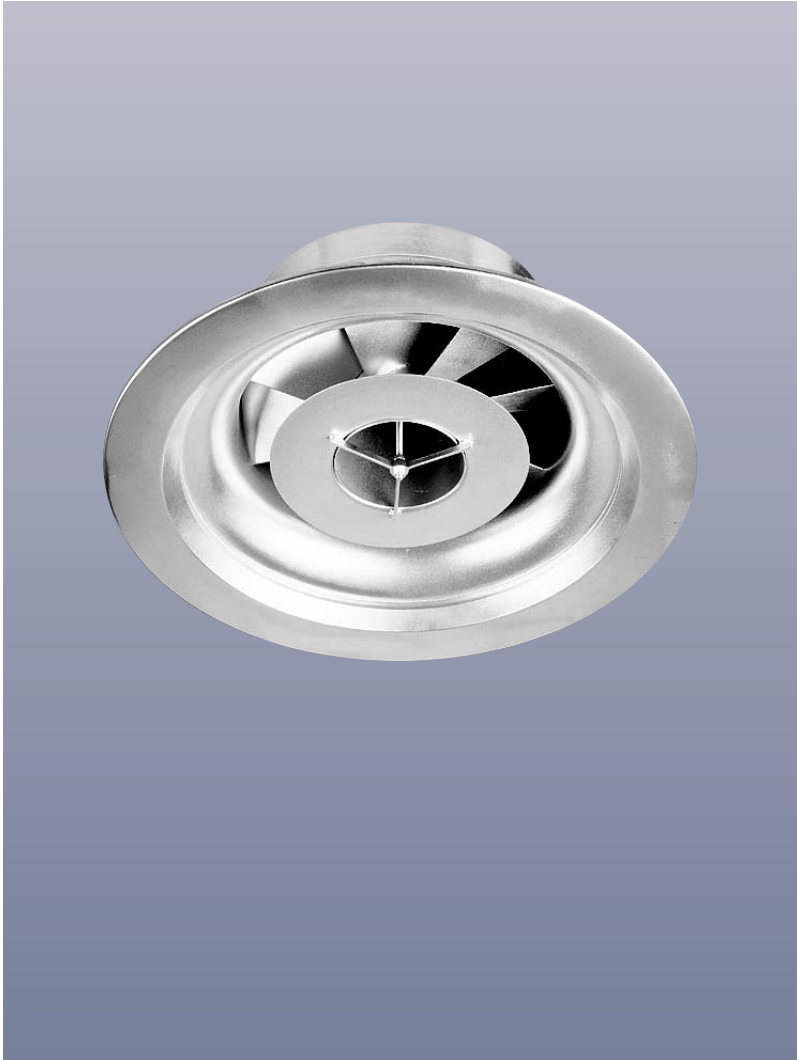

**Variable twist outlet  
with core tube DD-VK....**

### Preliminary remarks

The variable twist outlet with core tube produces turbulent mixing air flow. It is eminently suited for air distribution in areas without significant pollutant loads, primarily at large discharge heights.

A key feature of the optional air outlet type with round intake is its relatively low sound power level, making it suitable for use in rooms in the commercial sector, such as assembly rooms, sports halls, etc.

Patent rights registered.

### Construction design

The variable twist outlet consists of the outer cylinder 1 with intake 2 and exit 3, the eight fixed vanes 4 for the twist effect, the core tube 5 with lower diaphragm 6 and upper intake torus 7.

The variable twist outlet is available with a straight intake 2a or round intake 2b. The round intake type is best used in applications where the air outlet must meet high acoustic requirements. Connection type options are presented on page 4.

The air volume flow rate in the core tube 5 is altered with the valve disk 8. The valve disk can be operated by an electric servomotor 9 or manually.

For use in sports halls, the variable twist outlet in sizes DN 315 and DN 400 is available with a protective screen against balls to DIN 18 032, Part 3. Protective screens against balls for DN 600 and DN 710 on request.

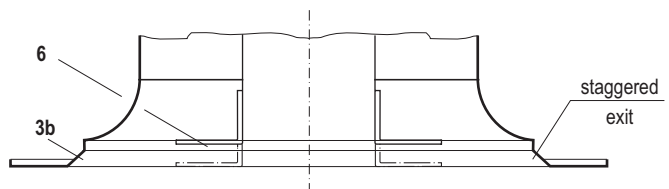
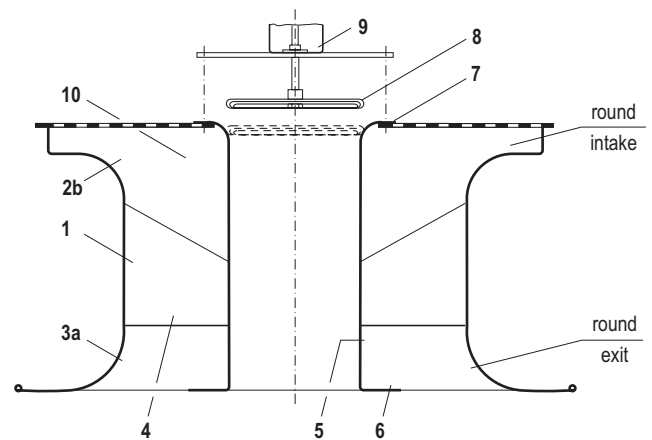
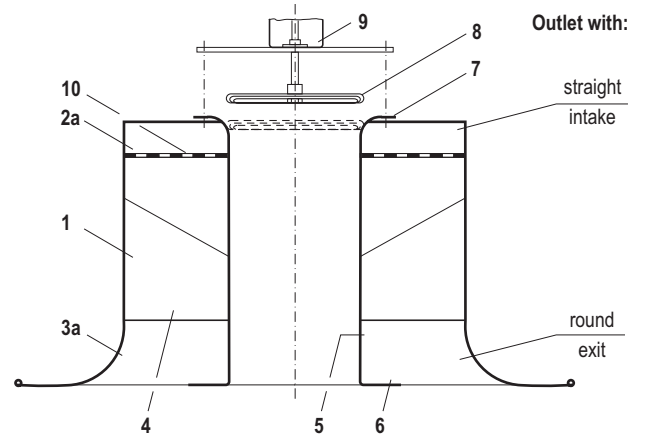

Nominal diameter		DN 315	DN 400	DN 600	DN 710
Volume flow rate	l/s	125 - 555	280 - 1055	555 - 2350	830 - 3050
	m³/h	450 - 2000	1000 - 3800	2000 - 8500	3000 - 11000
Discharge height with					
	- round exit	m	3 - 4.5	3.5 - 4.5	4 - 4.5
- staggered exit	m	4.5 - 8	4.5 - 12	4.5 - 14	5 - 15
Max. temperature difference $\Delta\vartheta$ between supply air and indoor air		- 12 K when cooling + 15 K when heating			

#### Key

- |                     |                           |
|---------------------|---------------------------|
| 1 Outer cylinder    | 5 Core tube               |
| 2a Intake, straight | 6 Diaphragm               |
| 2b Intake, round    | 7 Intake torus            |
| 3a Exit, round      | 8 Valve disk              |
| 3b Exit, staggered  | 9 Servomotor              |
| 4 Twist vane        | 10 Perforated metal sheet |

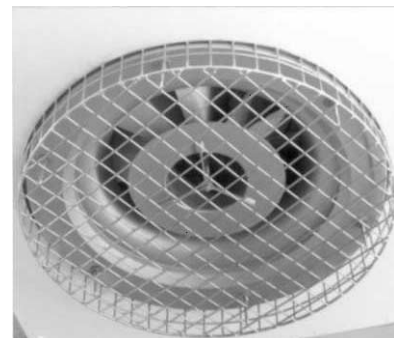

Variable twist outlet with straight intake at a spiral-seam duct,  
Left: Round exit, Right: Staggered exit

Variable twist outlet with protective screen against balls

### Mode of operation

Depending on connection type selected, the supply air enters the air outlet from the connection box or from the supply air duct (with duct connection). When the core tube is closed (valve disk in bottom position), the supply air flows only through the outer ring and over the twist vanes. This produces high-induction air jets with pronounced turbulence.

The round exit produces the Coanda effect and a radial jet deflection as a result. The horizontal, radial jets produced in this way cause a strong admixture of ambient air, resulting in a rapid equalization of supply air temperature with indoor air temperature.

Depending on the lift position of the valve disk, a certain share of the volume flow rate flows through the core tube. The maximum share is 30% of total volume flow rate. In this way a vertical support jet is formed which is superimposed on the radial air jets of the twist outlet and enlarges jet penetration depth into the room.

The round exit type forms a horizontal and a vertical jet direction. The vertical air jet lengthens with increasing support jet volume flow rate. When heating and at large discharge heights the air outlet operates with a large volume flow rate of the support jet.

In the outlet type with staggered exit, the support jet has a strong induction effect on the horizontal air jets. As the volume flow rate of the support jet increases, the supply air jets shift increasingly to the vertical direction; at max. support jet volume flow rate the entire supply air is discharged downwards. When cooling or at relatively low discharge heights, discharge is largely horizontal; when heating or from large heights it is vertically downwards.

The variable twist outlet with core tube fully satisfies high comfort requirements and is ideal for the comfort and the industrial sector, where turbulent mixing-air flow is required. A very even temperature and humidity distribution is achieved throughout the room.

The variable twist outlet can be installed freestanding in the room or in false ceilings. For installation in closed false ceilings the outlet with the staggered exit is provided with a ceiling spacer ring (page 9). A smooth jet deflection is also obtained in this installation option.

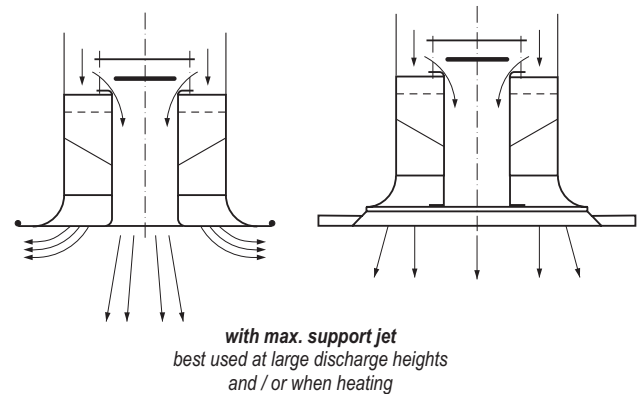
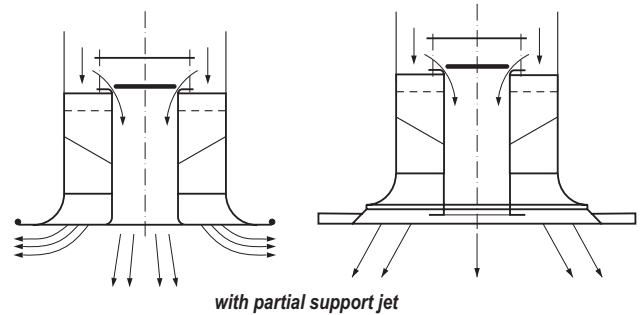
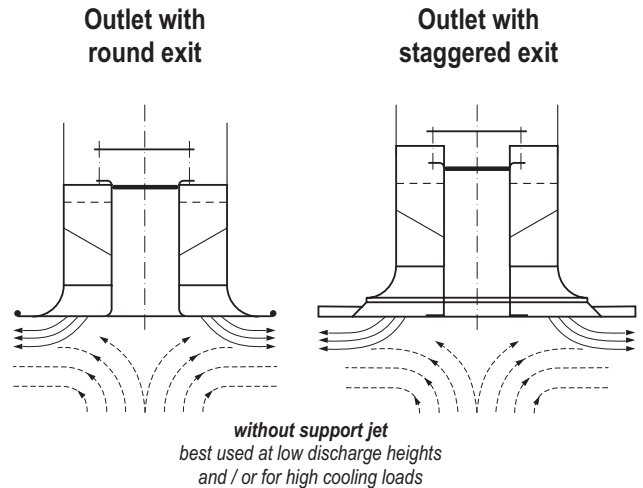

### Layout specifications

The round intake type is best used in rooms with high acoustic requirements. The outlets with round intake / staggered exit can be selected where the supply air performs a restricted heating function or at least 30% of the return air is collected in the floor zone during room heating with warm supply air.

# Variable twist outlet with core tube

## Connection types

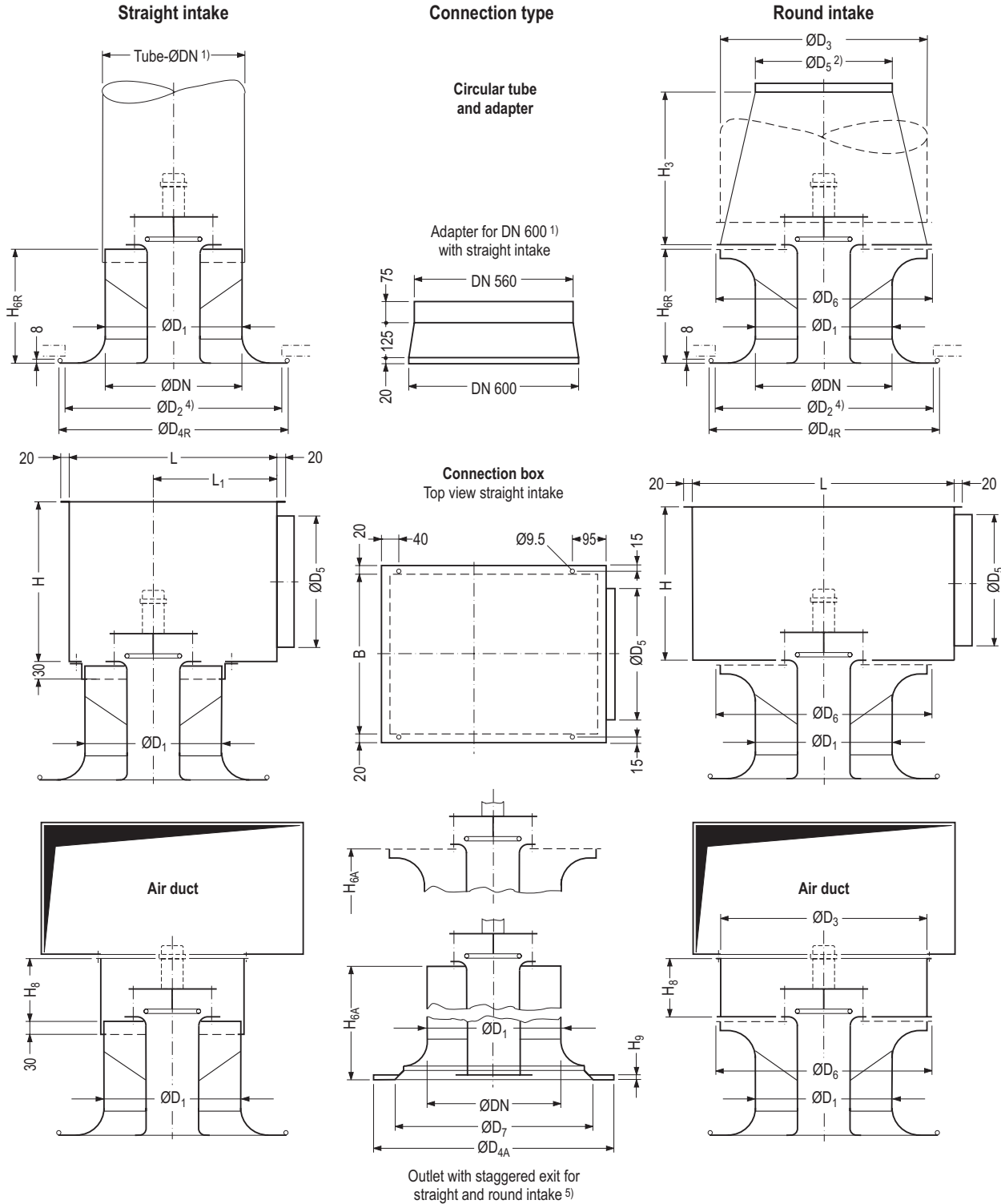

Nom.- Ø	All dimensions in mm																			Weight in kg <sup>3)</sup>						
	Straight intake									Round intake										Intake						
	DN	D <sub>1</sub>	D <sub>2</sub>	D <sub>4R</sub>	D <sub>5</sub>	D <sub>7</sub>	H	H <sub>8</sub>	H <sub>9</sub>	D <sub>4A</sub>	H <sub>6R</sub>	H <sub>6A</sub>	L	L <sub>1</sub>	B	D <sub>3</sub>	D <sub>4A</sub>	D <sub>6</sub>	H <sub>3</sub>	H <sub>6R</sub>	H <sub>6A</sub>	L	B	①	②	
315	314	500	525	314	442	365	≥240	10	550	260	285	420	237.5	365	450	600	490	400	260	285	610	500	2.5	11	3	15
400	399	610	650	399	560	450	≥300	10	700	300	330	505	280	450	560	760	600	500	300	330	720	610	4.5	16	5.5	20
600	598	870	950	598	852	650	≥450	15	1050	450	500	705	380	650	800	1140	860	750	450	500	960	850	13	30	16	39
710	708	1070	1100	708	1045	760	≥500	18	1245	475	535	815	435	760	1000	1245	1060	850	520	580	1160	1040	20	40	23	55

1) For size DN 600 the connection will be optionally made with a DN 560 adapter  
 2) For size DN 600 the connection is DN 560  
 3) Weight without servomotor, weight of servomotor approx. 0.5 kg to 0.8 kg

4) Ceiling cutout  
 5) Spacer ring for false ceiling installation, see page 9

① Twist outlet  
 ② Connection box

# Variable twist outlet with core tube

## Total pressure loss and sound power level

### Sound power level and pressure loss

Sound power level above octave band centre frequency and pressure loss are shown in the table below. Besides the air volume flow rate, the position of the valve disk or the share of support jet volume flow rate  $\dot{V}_S$  also have an influence on sound power level and pressure loss. In the air outlet type with straight intake, the sound power level

is highest when the volume flow rate of the support jet from the air outlet volume flow rate is  $\dot{V}_S = 10\%$  of total air volume flow rate  $\dot{V}_A$ . With the round intake outlet, the sound power level reaches maximum when the core tube is closed ( $\dot{V}_S = 0$ ). Pressure loss is always highest with a closed core tube.

Air outlet volume flow rate		Support jet volume flow rate	Straight intake								Support jet volume flow rate	Round intake								
			Total pressure loss	Sound power level $L_W$ in dB						Total pressure loss		Sound power level $L_W$ in dB								
$\dot{V}_A$	$\dot{V}_A$	$\dot{V}_S$	$\Delta p_t$	$L_{WA}$	Octave band centre frequency in Hz						$\dot{V}_S$	$\Delta p_t$	$L_{WA}$	Octave band centre frequency in Hz						
l/s	m <sup>3</sup> /h	% of $\dot{V}_A$	Pa	dB(A)	125	250	500	1 K	2 K	4 K	% of $\dot{V}$	Pa	dB(A)	125	250	500	1 K	2 K	4 K	
<b>DN 315</b>																				
330	1200	0	120	52	54	50	49	48	42	35	0	55	47	48	45	44	43	37	30	
		10	96	54	56	51	53	49	44	38		30	33	38	41	37	37	34	25	20
		30	60	48	46	40	43	46	35	33										
440	1600	0	200	60	58	54	55	57	52	44	0	100	55	58	51	49	52	47	37	
		10	170	62	58	62	61	56	52	45		30	58	45	47	42	43	43	32	22
		30	110	56	56	53	51	53	45	42										
555	2000	0	320	66	61	63	63	60	57	50	0	152	61	62	54	55	58	52	44	
		10	270	68	61	66	67	61	59	55		30	90	52	52	53	50	48	40	34
		30	160	62	59	63	59	56	54	41										
<b>DN 400</b>																				
555	2000	0	120	54	52	52	51	51	39	31	0	68	48	48	46	45	45	38	31	
		10	110	56	55	56	54	53	40	34		30	40	44	43	40	41	42	32	22
		30	75	49	50	46	46	47	37	31										
695	2500	0	190	59	60	60	56	56	46	40	0	110	54	55	53	52	50	45	40	
		10	165	62	60	61	59	59	46	40		30	63	50	49	48	49	47	38	32
		30	120	55	57	53	50	52	46	37										
835	3000	0	265	63	59	60	60	59	56	50	0	150	58	61	57	55	54	49	45	
		10	230	66	61	64	64	59	59	54		30	88	54	54	53	52	51	44	38
		30	165	60	59	61	57	54	52	44										
<b>DN 600</b>																				
1400	5000	0	160	58	57	54	56	53	50	40	0	95	53	54	51	51	50	43	34	
		10	140	60	57	54	57	57	53	45		30	50	46	45	46	44	43	34	22
		30	100	54	55	50	51	52	43	38										
1800	6500	0	270	65	60	63	64	60	55	50	0	160	60	60	59	58	56	50	46	
		10	235	67	60	65	65	61	60	55		30	85	54	57	53	50	49	43	37
		30	170	61	58	60	60	54	52	48										
2220	8000	0	400	70	64	67	70	63	60	57	0	240	66	70	64	63	61	58	50	
		10	360	72	66	69	72	65	63	60		30	125	59	64	58	56	56	51	41
		30	250	66	64	65	65	60	58	54										
<b>DN 710</b>																				
1950	7000	0	170	59	57	55	56	55	51	44	0	85	56	55	54	54	53	44	34	
		10	140	62	58	56	59	58	54	47		30	60	52	54	52	53	45	38	33
		30	90	56	57	54	55	50	47	40										
2500	9000	0	275	66	61	65	63	62	57	50	0	139	62	63	61	59	58	53	46	
		10	230	68	61	66	65	63	60	55		30	95	58	64	60	55	53	45	42
		30	150	63	60	61	62	54	56	50										
3050	11000	0	400	71	66	69	70	65	62	60	0	200	67	70	67	65	63	60	52	
		10	330	73	67	70	72	66	64	62		30	140	63	67	66	60	57	51	47
		30	220	68	65	66	68	62	60	56										

### Comfort criteria

The layout of the outlet will be based on compliance with the required maximum permissible indoor air velocities. First you have to determine the maximum specific volume flow rate  $\dot{V}_{Sp \max}$  depending on the indoor air velocity  $u$  and the discharge height  $H$  as per diagram 1.

The minimum outlet centre spacing  $t_{\min}$  will then be determined according to diagram 2 on the basis of the maximum specific volume flow rate and the outlet volume flow rate.

The layout criterion is based on

$$\Delta\vartheta_{\max} = -10 \text{ to } -12 \text{ K (chart 1)}$$

If the maximum temperature difference is lower,

$\dot{V}_{Sp \max}$  can be increased by the following percentage:

$$\Delta\vartheta_{\max} = -8 \text{ K} \Rightarrow \dot{V}_{Sp \max} \text{ 15 \% higher}$$

$$\Delta\vartheta_{\max} = -6 \text{ K} \Rightarrow \dot{V}_{Sp \max} \text{ 35 \% higher}$$

$$\Delta\vartheta_{\max} = -4 \text{ K} \Rightarrow \dot{V}_{Sp \max} \text{ 70 \% higher}$$

#### Key for all charts:

$\dot{V}_{A \max}$  = Max. volume flow rate per twist outlet depending on discharge height

$\dot{V}_{A \min H}$  = Min. volume flow rate per twist outlet when heating  $\Delta\vartheta = \dots\text{K}$

$\dot{V}_A$  = Selected volume flow rate per air outlet

$\dot{V}_{Sp \max}$  = Max. spec. volume flow rate per  $\text{m}^2$  floor area

$\dot{V}_s$  = Support jet volume flow rate

$u$  = Max. permissible indoor air velocity

$t_{\min}$  = Minimum air outlet spacing

### Maximum specific volume flow rate

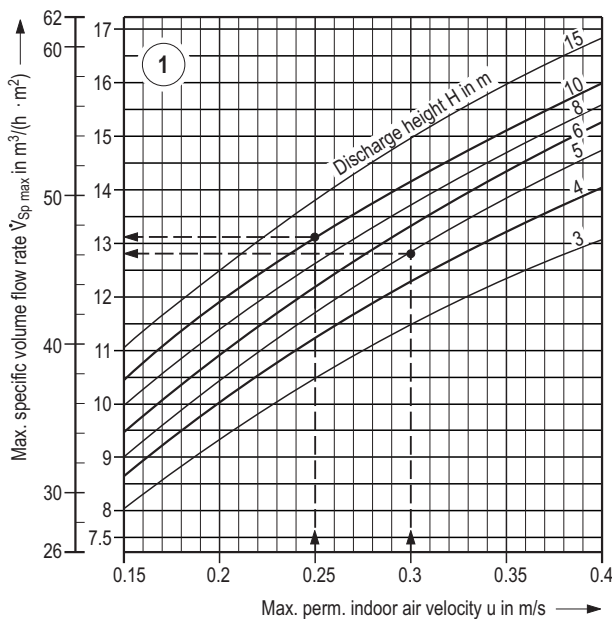

### Minimum air outlet centre spacing

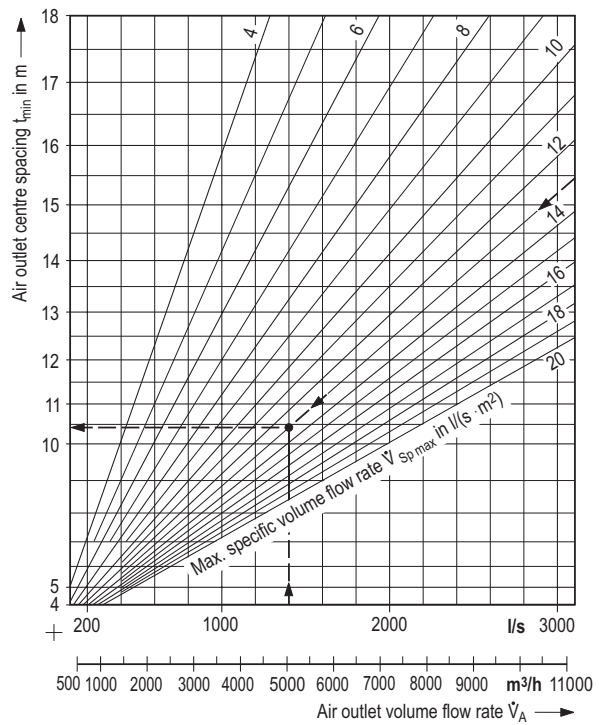
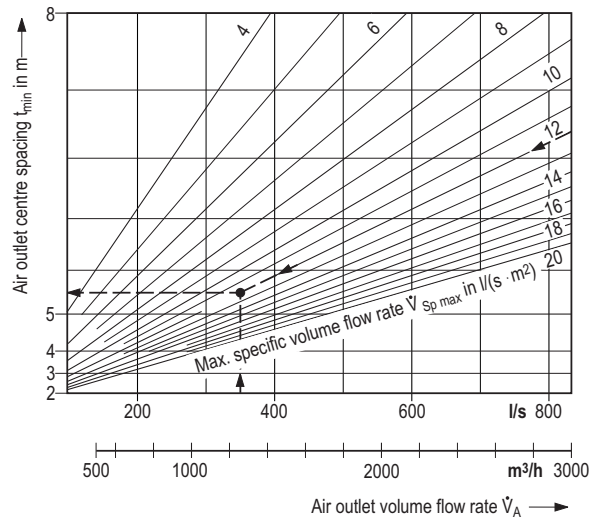

# Variable twist outlet with core tube

## Nomogram DN 315 and DN 400

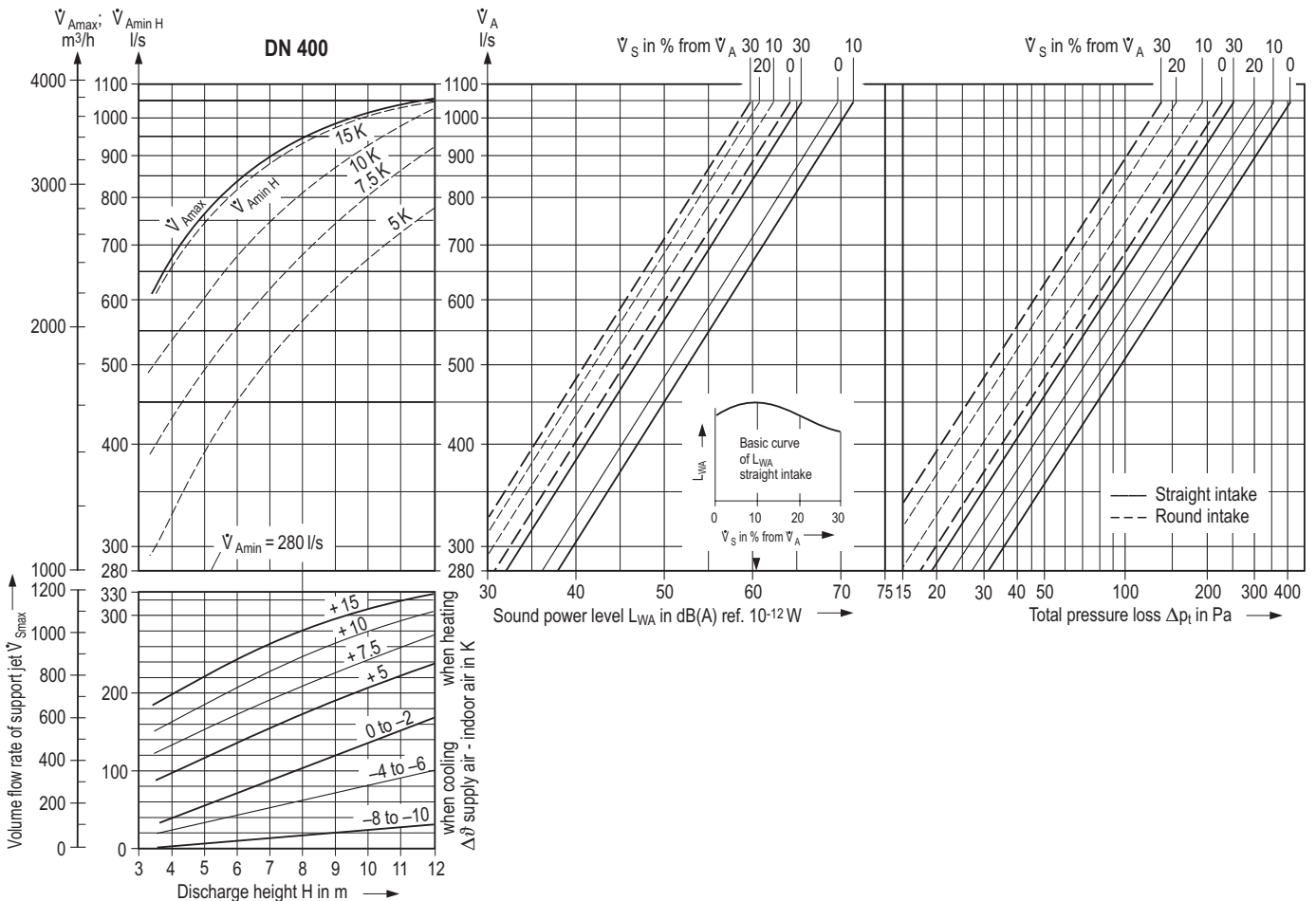
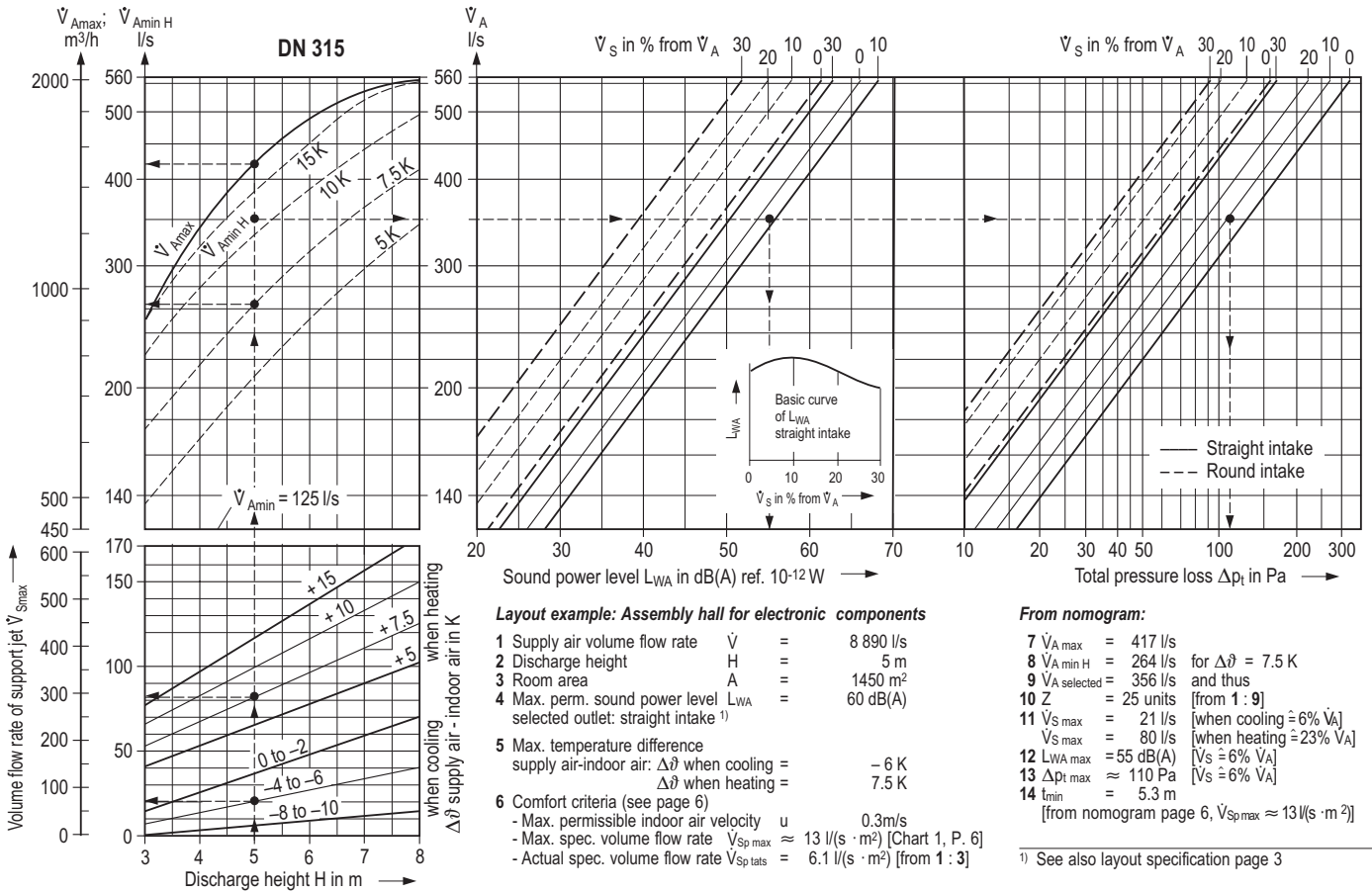

# Variable twist outlet with core tube

## Nomogram DN 600 and DN 710

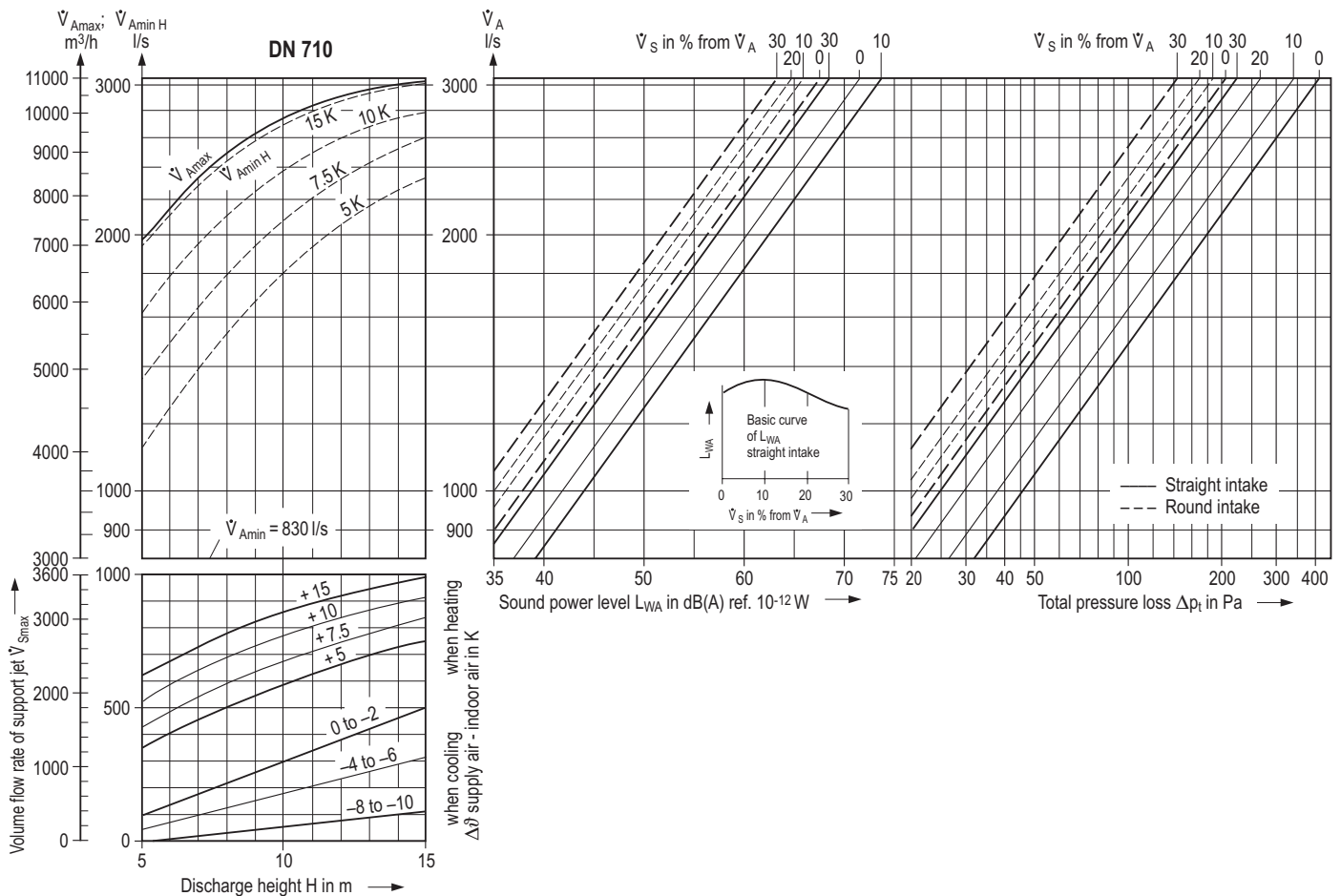
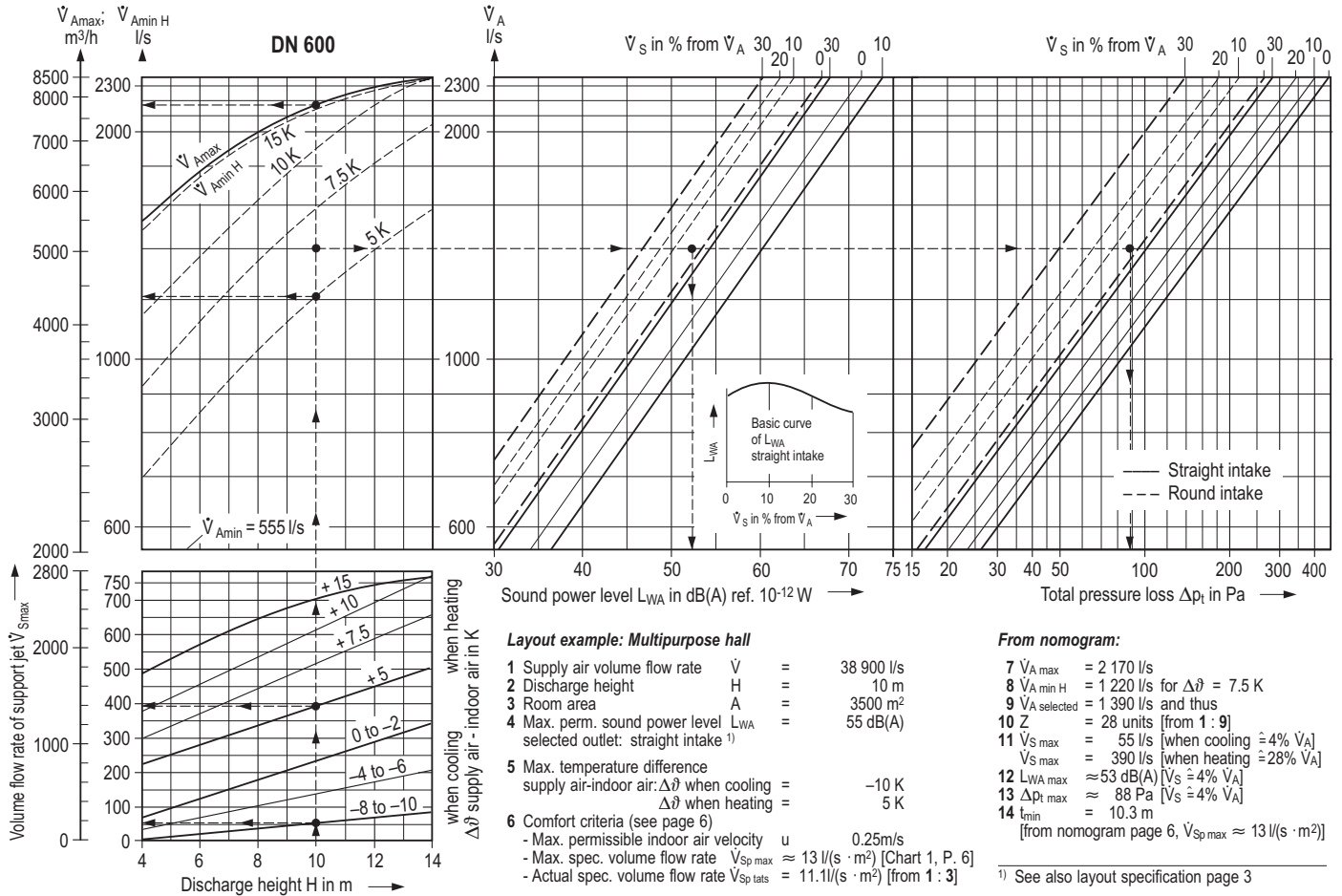

## Spacer ring for false ceiling installation

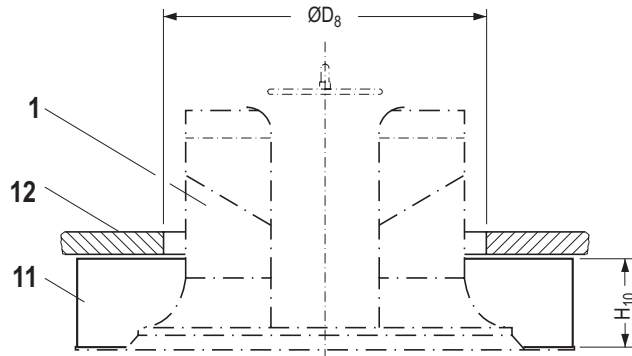

Nom.-Ø DN	Dimensions in mm	
	D <sub>8</sub> <sup>1)</sup>	H <sub>10</sub>
315	355	80
400	440	100
600	650	120
710	785	120

### Key

- 1 Twist outlet-outer cylinder
- 11 Ceiling spacer ring
- 12 False ceiling

<sup>1)</sup> Ceiling cutout

## Features

- Turbulent mixing air flow
- Volume flow rate range of 125 to 3050 l/s (450 to 11 000 m<sup>3</sup>/h)
- Jet penetration depth adaptable to room height and heat load
- Even temperature and humidity distribution throughout room
- Stepless alteration of discharge direction horizontal to vertically downwards
- Adjustment manual or with servomotor
- Discharge heights of 3 m to 15 m
- Max. temperature difference supply air and indoor air – 12 K when cooling and + 15 K when heating
- Sizes DN 315, DN 400, DN 600, DN 710; DN 315 and DN 400 available with protective screen against balls
- Material aluminium
- Different connection types
- Can be fitted with the temperature difference control unit from KRANTZ KOMPONENTEN for optimum jet penetration depth
- Acceleration of heating up operation
- For commercial sector and industry



*Jet spread in heating mode made visible with smoke tracer: The warm, vertical supply air jets penetrate deep into the occupied zone.*

## Type code

DD – VK – DN – – – –

-----  
Ceiling twist outlet  
-----  
Function / Kind  
-----  
Size  
-----  
Connection type  
-----  
Type  
-----  
Adjustment

Please note,  
type code is new,  
see last page.

### Function / Kind

V = adjustable  
K = with core tube

### Size

DN 315, DN 400,  
DN 600, DN 710

### Connection type

R = Duct connection with straight intake  
A = Adapter with round intake  
K = Connection box

### Type

GR = with straight intake and round exit  
GA = with straight intake and staggered exit  
RR = with round intake and round exit  
RA = with round intake and staggered exit

### Adjustment

M = manual  
E = with electric servomotor

- Air outlet with straight intake and round exit,
- Air outlet with straight intake and staggered exit,
- Air outlet with round intake and round exit,
- Air outlet with round intake and staggered exit,

### Duct connection by

- direct connection to circular tube (for straight intake),
- adapter made of galvanized sheet steel for air outlet with round intake,
- adapter made of galvanized sheet steel for air outlet DN 600 with straight intake,
- connection box with lateral spigot, made of galvanized sheet steel,

### Technical data

Volume flow rate: ..... l/s (m<sup>3</sup>/h)  
Size: DN .....  
Perm. sound power level: ..... dB(A) ref. 10<sup>-12</sup> W

### Valve disk adjustment

- manual,
- with electric servomotor,
- Spacer ring for the air outlet with staggered exit for installation in closed false ceiling,
- Protective screen against balls <sup>1)</sup> to DIN 18 032, Part 3, Twist outlet
  - installed flush with ceiling,
  - suspended,

Visible air outlet parts painted to RAL .....

Make: KRANTZ KOMPONENTEN

Type: DD – VK – DN – – – –

## Tender text

..... Units

Variable twist outlet, designed for air distribution at large discharge heights, with high-induction, radial, horizontal air jets and an adjustable, vertical support jet, consisting of:

Outer cylinder and core tube with interjacent twist vanes,  
Perforated metal sheet for even supply air distribution and sufficient support jet volume flow rate,  
Valve disk for support jet regulation,  
Material aluminium,

Subject to technical alterations!

<sup>1)</sup> Available for DN 315 and DN 400; DN 600 and DN 710 on request.



Variable twist outlet with core tube

## Type code

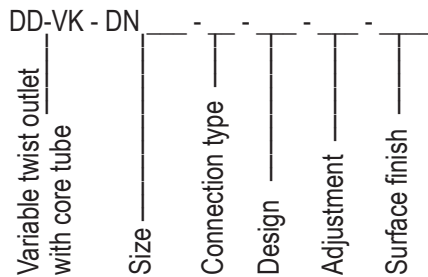

## Size

- 315 = DN 315
- 400 = DN 400
- 600 = DN 600
- 710 = DN 710

## Connection type

- R = Duct connection with rivet or screw connection
- K = Connection box

## Design

- GR = with straight intake and rounded exit
- GA = with straight intake and staggered exit
- RR = with rounded intake and rounded exit
- RA = with rounded intake and staggered exit

## Adjustment

Size	DN 315		DN 400		DN 600		DN 710	
	rounded	staggered	rounded	staggered	rounded	staggered	rounded	staggered
Exit								
MA = manual	•	•	•	•	•	•	•	•
E22 = „Siemens servomotor, 0-10 V modulation“, stroke drive type GDB161.2E	•		•		•		•	
E23 = „Siemens servomotor, 3-point type, 24 V“, stroke drive type GDB131.2E	•		•		•		•	
E24 = „Siemens servomotor, 3-point type, 230 V“, stroke drive type GDB331.2E	•		•		•		•	
E25 = „Siemens servomotor, 0-10 V modulation“, stroke drive type GLB161.2E		•		•				
E26 = „Siemens servomotor, 3-point type, 24 V“, stroke drive type GLB131.2E		•		•				
E27 = „Siemens servomotor, 3-point type, 230 V“, stroke drive type GLB331.2E		•		•				
E28 = „Siemens servomotor, 0-10 V modulation“, stroke drive type GBB163.2E						•		•
E29 = „Siemens servomotor, 3-point type, 24 V“, stroke drive type GBB131.2E						•		•
E30 = „Siemens servomotor, 3-point type, 230 V“, stroke drive type GBB331.2E						•		•

## Surface finish

.... = Face painted to RAL ....

Subject to technical alteration.