

Technical Selection – for Asia / Pacific



Radial outlet RA-N3....

Preliminary remarks

KRANTZ KOMponenten radial outlets of type RA-N3 have 24 fixed radial vanes. They generate high-quality, diffuse supply according to the principle of turbulent mixing air flow.

The supply air is discharged horizontally. The highly turbulent supply air jets induce the indoor air, which leads to rapid equalisation of supply air and indoor air temperature and rapid jet velocity decay.

The RA-N3 produces extremely comfortable indoor air conditions and is eminently suitable for offices and administrative buildings. They are intended for installation in suspended ceiling systems.

The RA-N3 radial outlet is available in 2 sizes for volume flow rates of 14 to 400 l/s (at $\Delta\vartheta = -15$ K). The discharge height is 2.4 to 4.5 m, the maximum temperature difference between supply air and indoor air is -15 K when cooling, and $+10$ K at 3 m and $+5$ K at 4.5 m height when heating.



Radial outlet with square visible face ¹⁾ and connection box ³⁾

- Key:**
- 1 RA-N3 radial outlet
 - 2 Collar ²⁾
 - 3 Connection box
 - 4 Spigot with volume flow damper adjustable from room
 - 5 Fastener for RA-N3
 - 6 Hanging bracket
 - 7 Insulation

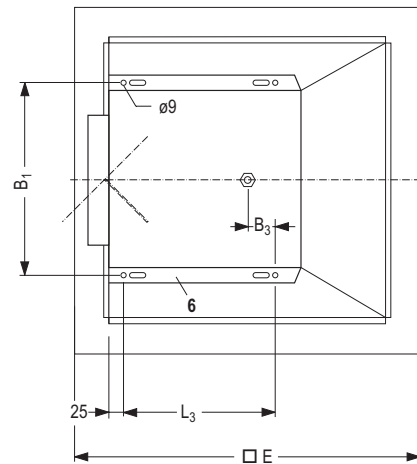
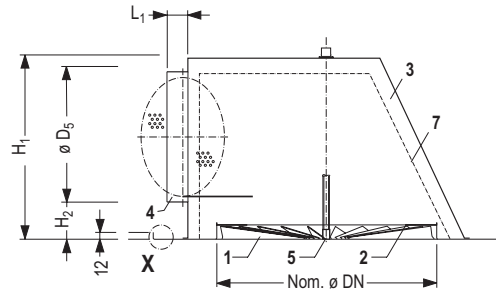

Detail X
Type QII
90° turn-up for installation in coffered ceilings

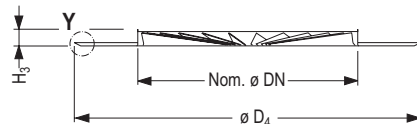

Detail Y
Type R
Flush contact edge for ceiling attachment

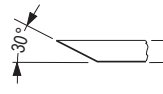

Nominal diameter DN	Ceiling grid	Collar size	Volume flow rate ⁴⁾			Dimensions in mm											Weight in kg	
			\dot{V} l/s at $\Delta\vartheta = -15$ K	\dot{V} l/s at $\Delta\vartheta = -12$ K	$\dot{V}_{min}^{5)}$ in l/s With Perf. $\Delta\vartheta = -10$ K	□ E ¹⁾ mm	$\varnothing D_5$ mm	L1 mm	L3 mm	B1 mm	B3 mm	H1 mm	H2 mm	H3 mm	$\varnothing D_4$ mm	Air outlet	Con-nection box	
DN 350	□ 400 □ 450 □ 500 □ 600	0	55 – 175	50 – 175	80 – 160	□ 395 □ 445 □ 495 □ 595	249	60	255	316	45	340	66	28	470	to	4.8	
		1	44 – 140	40 – 140	65 – 125													
		2	38 – 120	35 – 120	55 – 110													
		3	33 – 95	30 – 95	45 – 90													
		4	24 – 75	22 – 75	34 – 70													
		5	18 – 55	16 – 55	25 – 50													
DN 500	□ 600	0	130 – 400	120 – 400	180 – 350	□ 595	349	60	300	352	40	460	82	36	675	to	7.4	
		1	120 – 320	100 – 320	145 – 300													
		2	100 – 290	90 – 290	130 – 260													
		3	75 – 240	70 – 240	110 – 210													
		4	60 – 180	55 – 180	85 – 170													
		5	50 – 145	45 – 145	65 – 135													

1) Rectangular and circular design available on request

2) Collar for 1-way, 2-way and 3-way discharge available on request

3) Reducer for outlet connection to duct, without connection box, available on request

4) Δp_r less than 45 Pa, L_p per diffuser less than NC30 (based on 10 dB(A) room absorption), \dot{V}_{min} valid for diffuser flush with closed ceiling

5) Perforated face adds 3 dB and increases pressure loss by 10%

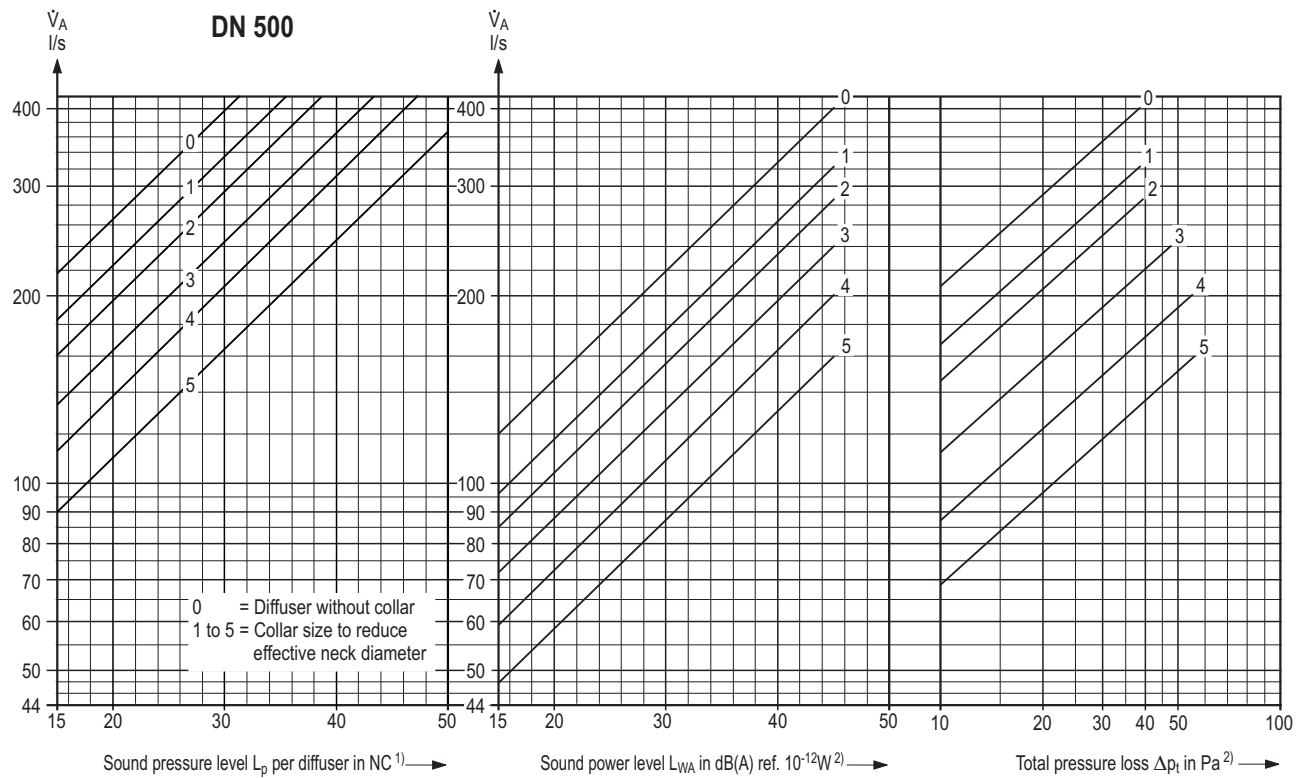
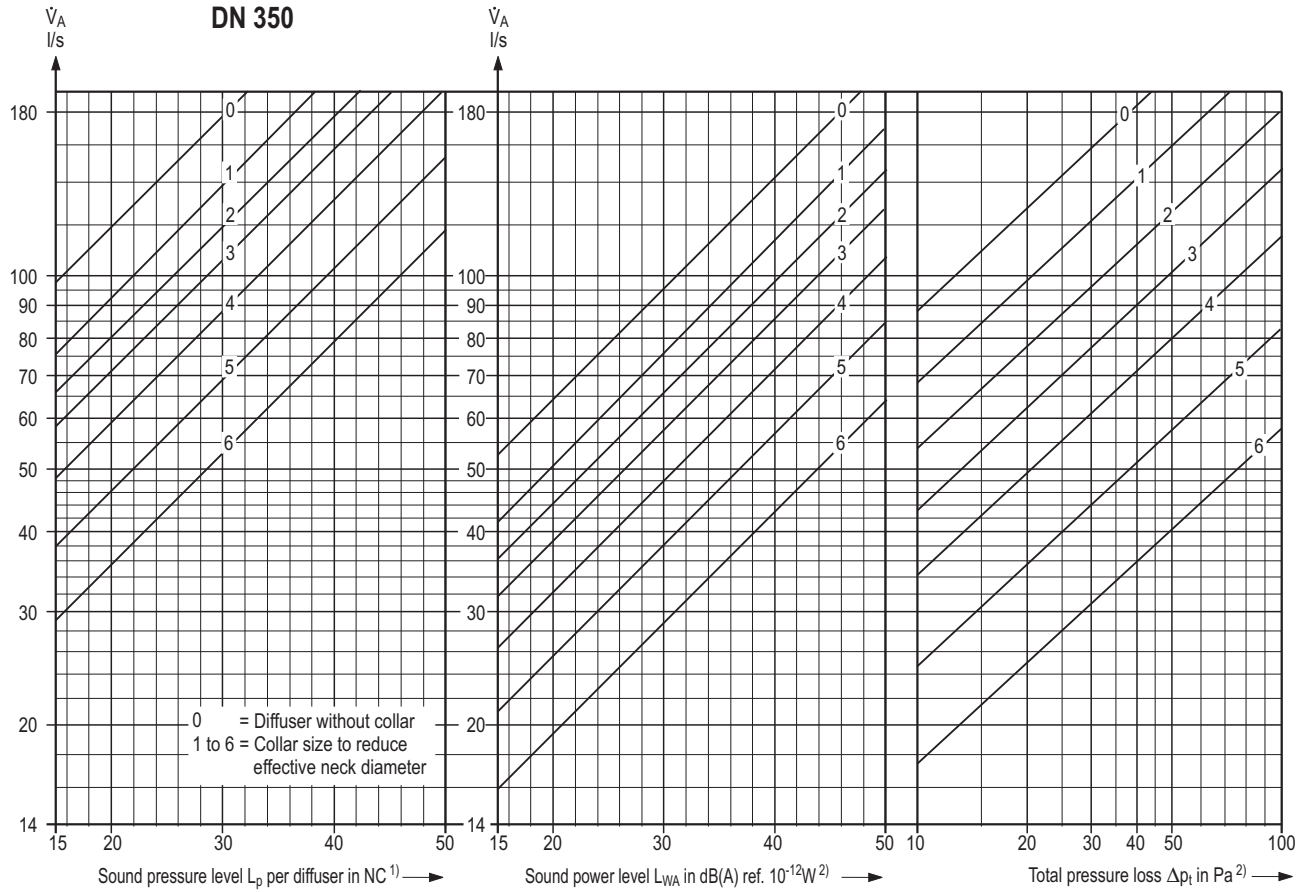

DS 4134 AUS Bl. 3 05.2006

Note: Without acoustic lining the sound power level of the connection box is up to 3 dB(A) higher

- 1) Based on 10 dB(A) room absorption
- 2) Values apply for 4-way discharge

Correction table for 3-way and 2-way discharge:

	Sound power level	Pressure loss
3-way discharge	+ 5 dB(A)	To be multiplied by 1.35
2-way discharge, symmetrical	+ 9 dB(A)	To be multiplied by 2.0
2-way discharge, asymmetrical	+ 10 dB(A)	To be multiplied by 2.3

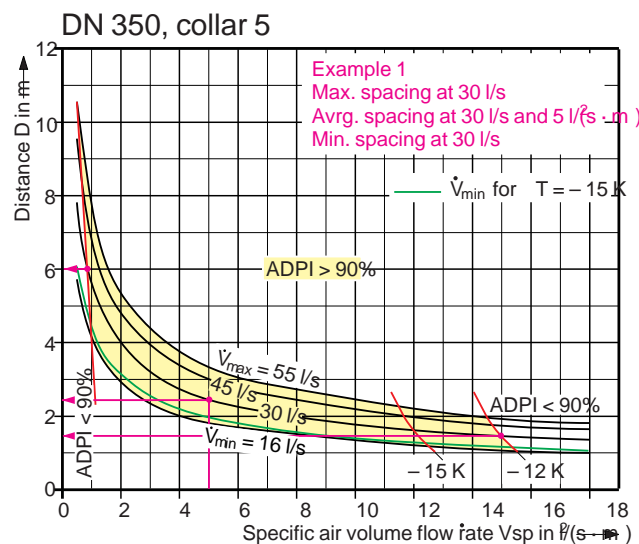
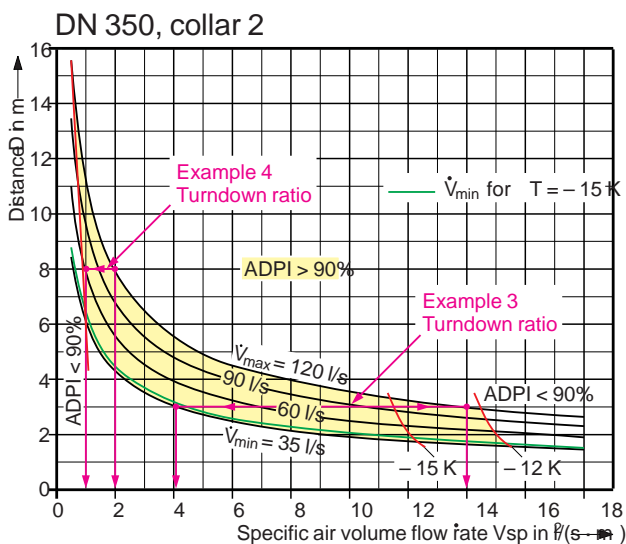
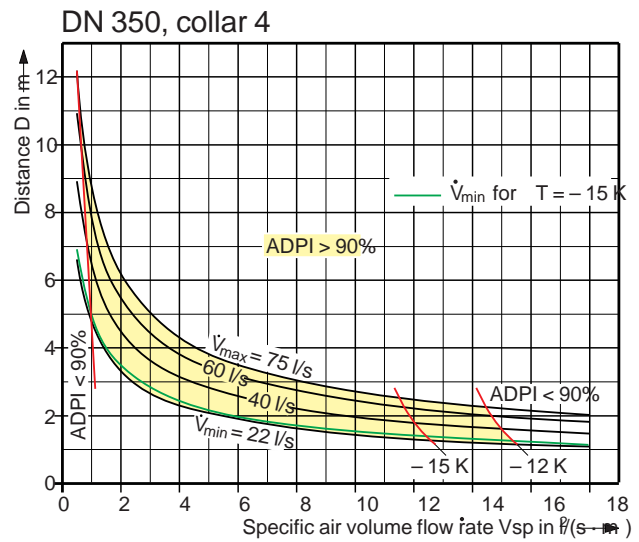
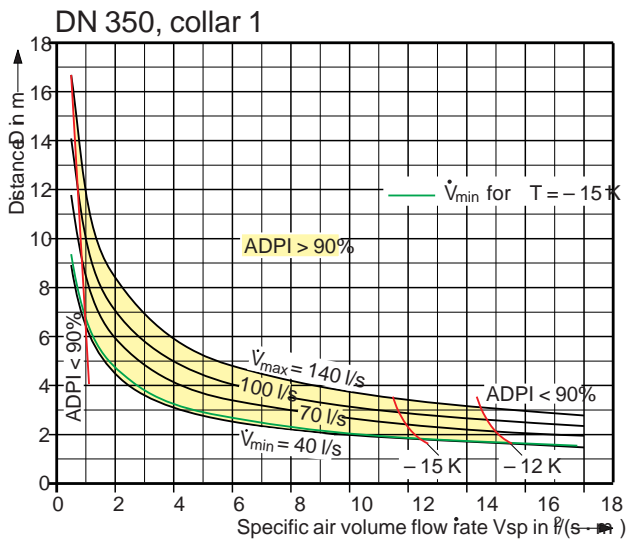
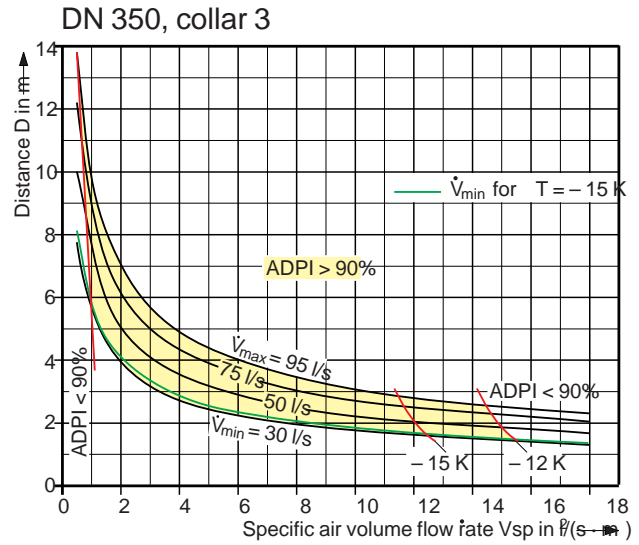
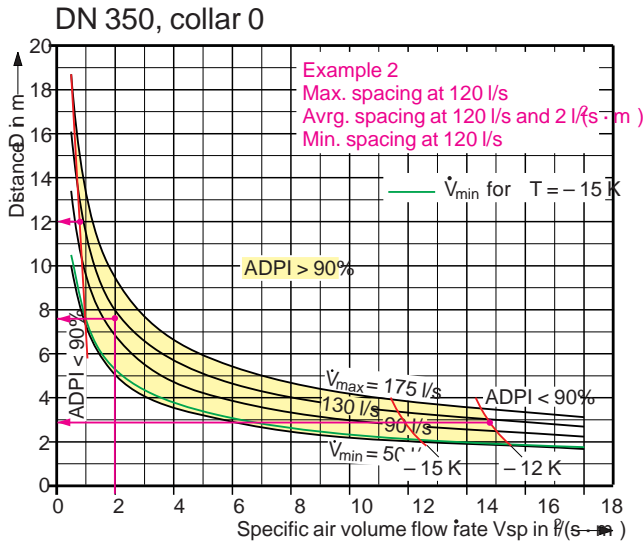

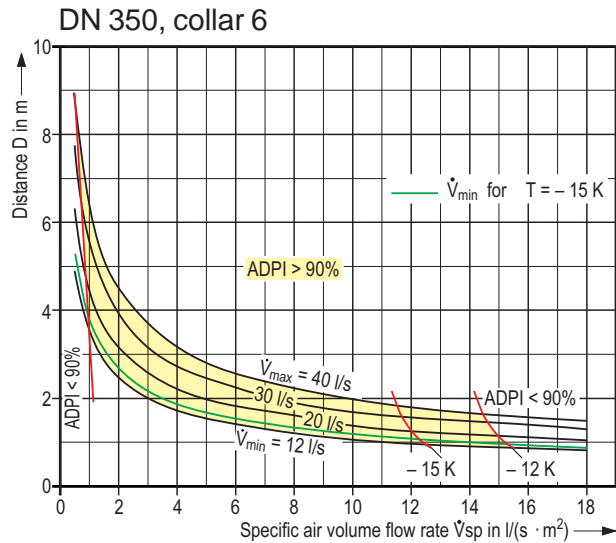

Air Diffusion Performance Index (ADPI)

Air Diffusion Performance Index (ADPI) is a single number that rates the air diffusion performance of a system of diffusers operating in a space. ADPI is affected by such factors as diffuser type and location, airflow rates, heat loads and location, space geometry, etc. To determine ADPI, air velocity and air temperature measurements are made at four different heights at a multitude of locations throughout the occupied zone in accordance with ASHRAE Standard 113. For each measurement point, ADPI evaluates the combined effect of local velocity and temperature deviation from average room temperature to establish whether the threat of draught or stagnation exists at that point. The temperature deviation and air velocity effects are additive, so that an increased threat of draught exists at points where the air velocity is high and the local temperature is cooler than average; similarly, an increased threat of stagnation exists at points where the air velocity is low and the local temperature is higher than average. The percentage of points that pass the ADPI test (i.e. do not fail due to draught or stagnation) determines the ADPI percentage attained. According to ASHRAE, for an office environment in cooling mode, the design goal should be an ADPI of 80%. To ensure enhanced conditions of comfort, Krantz diffuser spacing graphs are based on satisfying an even more stringent ADPI of 90%.

Example 1:

Constant volume airflow at 30 l/s and 5 l/(s · m²)

Choose RA-N3-DN 350-5 (i.e. with collar 5)

Minimum permissible diffuser spacing to satisfy ADPI 90% is 1.5 m (minimum permissible distance to wall is half this figure, i.e. 1.5 m / 2 = 0.75 m).

Maximum permissible diffuser spacing to satisfy ADPI 90% is 6 m (maximum permissible distance to wall is half this figure, i.e. 6 m / 2 = 3 m).

Average diffuser spacing is 2.5 m.

Example 2:

Constant volume airflow at 120 l/s and 2 l/(s · m²)

Choose RA-N3-DN 350-0 (i.e. without collar)

Minimum permissible diffuser spacing to satisfy ADPI 90% is 2.7 m (minimum permissible distance to wall is half this figure, i.e. 2.7 m / 2 = 1.35 m).

Maximum permissible diffuser spacing to satisfy ADPI 90% is 12 m (maximum permissible distance to wall is half this figure, i.e. 12 m / 2 = 6 m).

Average diffuser spacing is 7.5 m.

Example 3:

Perimeter zone - VAV with 120 l/s and 3 m spacing

Choose RA-N3-DN 350-2 (i.e. with collar 2)

At 120 l/s per diffuser the specific airflow at 3 m spacing is approx 14 l/(s · m²).

This system can be turned down to 35 l/s per diffuser, equating to approx 4 l/(s · m²).

Therefore, turndown to 29% (i.e. 35/120 l/s) is permissible.

Example 4:

Centre zone - VAV with 120 l/s and 8 m spacing

Choose RA-N3-DN 350-2 (i.e. with collar 2)

At 120 l/s per diffuser the specific airflow at 8 m spacing is approx 2 l/(s · m²).

This system can be turned down to 60 l/s per diffuser (without dropping below 90% ADPI), equating to approx 1 l/(s · m²).

Therefore, turndown to 50% (i.e. 60/120 l/s) is permissible.

DN 500, collar 0

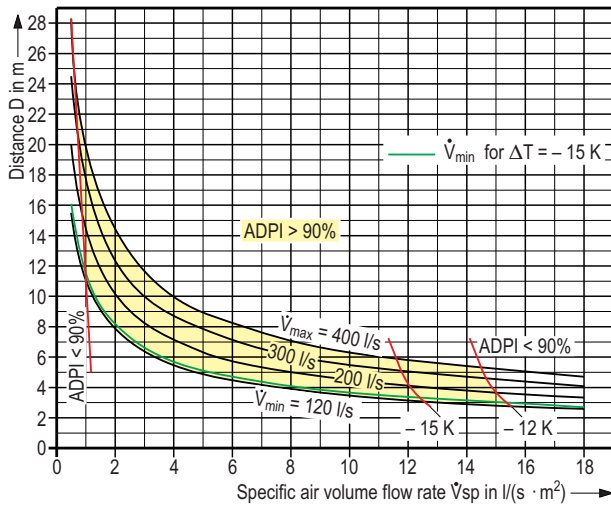

DN 500, collar 3

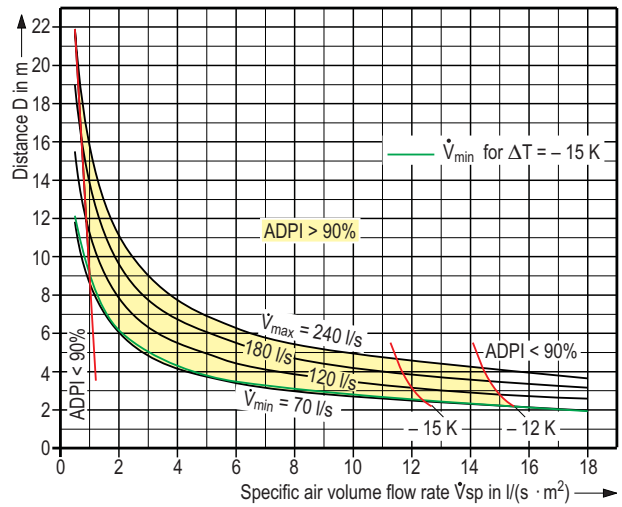

DN 500, collar 1

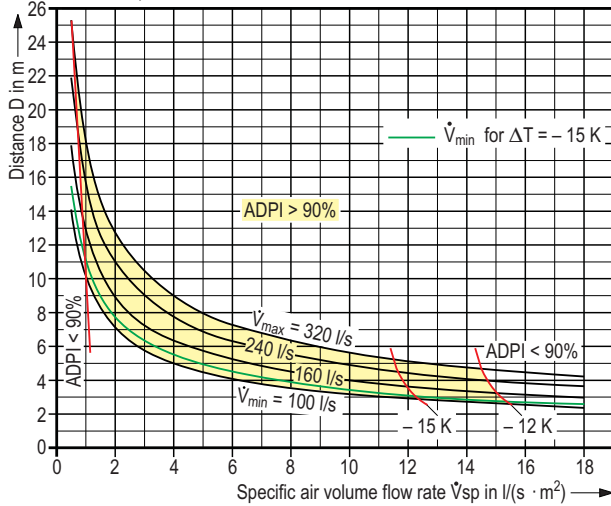

DN 500, collar 4

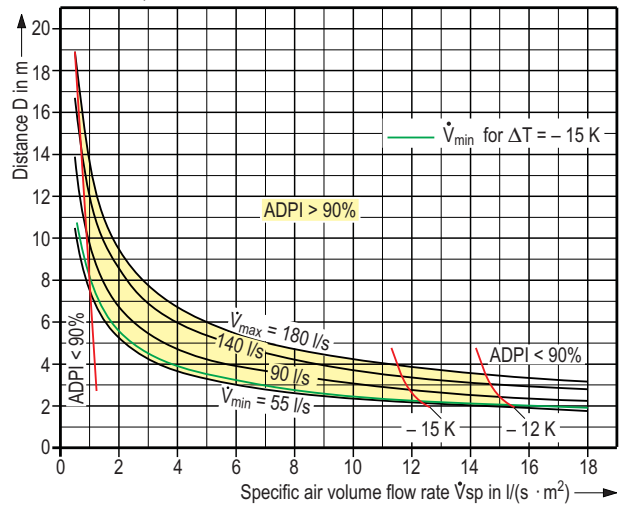

DN 500, collar 2

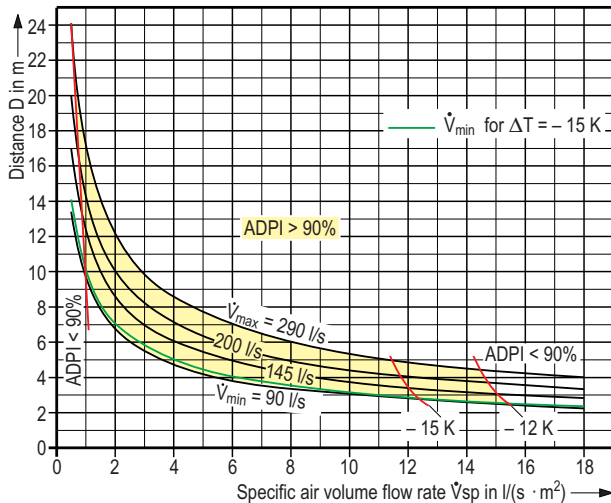

DN 500, collar 5

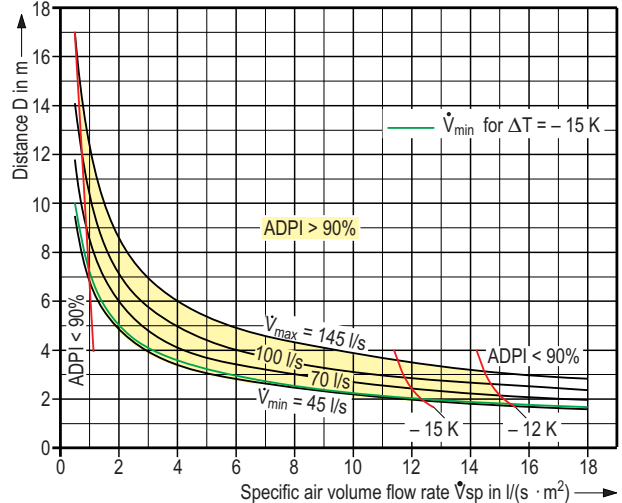

Features

- For high-quality, diffuse indoor air flow
- Suitable for VAV systems
- Stable supply air jets, also at minimum volume flow rate
- Available in 2 sizes: DN 350 and DN 500. DN 350 for 7 ranges of volume flow rate (collar type 0 to 6), DN 500 for 6 ranges (collar type 0 to 5)
- Discharge height 2.4 to 4.5 m
- Maximum temperature difference between supply air and indoor air: -15 K when cooling, and +10 K at 3 m and + 5 K at 4.5 m height when heating
- Low sound power level and pressure loss
- For installation flush with suspended false ceilings or below closed false ceilings
- Outlet element easy to mount or demount from the room
- The connection boxes are stackable, which reduces their volume for transport and storage
- Outlet element made from powder-coated sheet metal, connection box made from sendzimir-galvanised sheet metal
- Perforation increases total pressure loss by 10% and adds 3 dB(A) to the sound power level

Type code

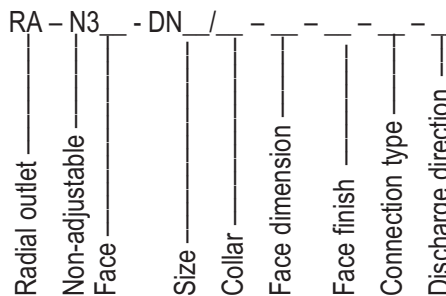

Face

- R = Circular visible face with flush contact edge (4 mm / 30°) for closed false ceilings
- QII = Square visible face with 90° turn-up (12 mm) for coffered ceilings

Size

- DN 350 = Nominal neck diameter 350 mm
- DN 500 = Nominal neck diameter 500 mm

Collar

0 = No collar; or collar size 1-6 depending on airflow

Face dimension

- for **DN 350**: 395 x 395 mm up to 595 x 595 mm
- for **DN 500**: 595 x 595 mm

Options:

Face finish

P = Perforated face

Connection type

- F = With connection box type F
- D = With damper
- I = With insulation

Discharge direction

- 4 = 4-way discharge, 3 = 3-way discharge
- 2s = 2-way symmetrical 2a = 2-way asymmetrical

Face finish



P = Perforated face

Discharge direction (viewed from behind)

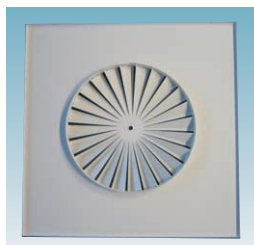

4 = 4-way discharge

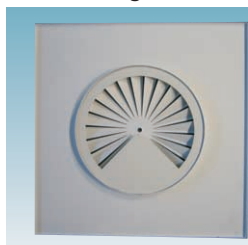

3 = 3-way discharge



2s = 2-way discharge symmetrical



2a = 2-way discharge asymmetrical

- Subject to technical alteration -



www.krantz.com.au
info@krantz.com.au